

FCL

Universal and floor installation

- Standard internal three-way valve
- Version with 2-way valve for variable water flow rate systems
- Version without valves



DESCRIPTION

4-way cassettes that can be installed in any type of 2- or 4-pipe system with any heat generator, even at low temperatures. Thanks to the selection of versions and configurations, it's easy to choose the best solution for every need.

FEATURES

Intake grid and distribution of the air

The recovery and air diffusion grille has an elegant design. In plastic, RAL 9010.

The dimensions of the first nine sizes respect the 600x600mm modularity of false ceilings, whereas the larger sizes (measuring 800x800mm) are designed for quiet operation and optimum performance.

Load-bearing structure

Models with a 600x600 module have a reinforced load-bearing structure with side panels in galvanised steel sheet, thermally insulated with internal polystyrene foam elements.

The structure of models with a 800x800 module is made entirely of galvanised steel sheet, thermally insulated with polyethylene foam on the inside and with an anti-condensate felt coating.

Ventilation group

Formed of a particularly quiet axial-centrifugal fan, statically and dynamically balanced.

The single-phase electric motor offers three or four speeds (depending on the size), is mounted on anti-vibration supports, and has a permanently enabled condenser.

Heat exchanger coil

Heat exchanger with shaped profile to increase the exchange surface, and easily accessible drain valves.

There are models with a single coil for 2-pipe systems, with the possibility to add an electric heater too, and models with two coils for 4-pipe systems.

There is the possibility to combine outside air with the inlet ambient air, and to distribute it in separate rooms.

The coil is not suitable for use in corrosive atmosphere or in environments where aluminium may be subject to corrosion.

Condensate drip

Condensation drip tray in one piece, with V0 self-extinguishing level and overmoulding to insulation in expanded polystyrene with flame retardant additive.

Air filter

Air filter easily removed and cleaned, self-supporting structure, characterised by a high efficiency and low pressure drops, with class-V0 fire resistance (UL 94).

Versions

FCL Standard with internal 3-way valve

V2 With internal 2-way valve

VL Without internal valve

ACCESSORIES

Intake grids and distribution of the air, compulsory accessory

GLF10: Recovery and air supply grille in plastic, RAL 9010 colour, measuring 600x600; adapts perfectly to standard false ceilings without overlapping parts. Intake is in the central part, where the easily removable air filter is housed. Delivery is via the perimeter slits with manually orientated fins. Must be combined with a wall-mounted panel. (size 800x800 not available).

GLF10EH: Recovery and air supply grille in plastic, RAL 9010 colour, measuring 600x600; adapts perfectly to standard false ceilings without overlapping parts. Suitable for use with the RXLE heater (managed via an external thermostat, supplied by Aermec or another manufacturer). Intake is in the central part, where the easily removable air filter is housed. Delivery is via the perimeter slits that can be orientated with the remote control (size 800x800 not available).

GLF10M: Recovery and air supply grille in plastic, RAL 9010 colour, measuring 600x600; adapts perfectly to standard false ceilings without overlapping parts. Fitted with an infrared receiver with an emergency operation button. Intake is in the central part, where the easily remov-

able air filter is housed. Delivery is via the perimeter slits that can be orientated with the remote control (size 800x800 not available).

GLF10N: Recovery and air supply grille in plastic, RAL 9010 colour, measuring 600x600; adapts perfectly to standard false ceilings without overlapping parts. Fitted with a thermostat board that necessarily requires the installation of the VMF-E4 or VMF-IR panel as well. Intake is in the central part, where the easily removable air filter is housed. Delivery is via the perimeter slits that can be orientated with the remote control (size 800x800 not available).

GLL10: Recovery and air supply grille in plastic, RAL 9010 colour, measuring 600x600; adapts perfectly to standard false ceilings without overlapping parts. Intake is in the central part, where the easily removable air filter is housed. Delivery is via the perimeter slits that can be manually orientated. Must be combined with a wall-mounted panel.

GLL10M: Recovery and air supply grille in plastic, RAL 9010 colour, measuring 600x600; adapts perfectly to standard false ceilings without overlapping parts. Fitted with an infrared receiver with an emergency operation button, and a remote control. Intake is in the central part, where the easily removable air filter is housed. Delivery is via the perimeter slits that can be orientated with the remote control.

GLL10N: Recovery and air supply grille in plastic, RAL 9010 colour, measuring 600x600; adapts perfectly to standard false ceilings without overlapping parts. Fitted with a thermostat board that necessarily requires the installation of the VMF-E4X panel as well, and suitable for use with the RXLE heater. Intake is in the central part, where the easily removable air filter is housed. Delivery is via the perimeter slits that can be orientated with the remote control.

GLL10R: Recovery and air supply grille in plastic, RAL 9010 colour, measuring 600x600; adapts perfectly to standard false ceilings without overlapping parts. Fitted with an infrared receiver with an emergency operation button, and a remote control. Suitable for use with the RXLE heater. Intake is in the central part, where the easily removable air filter is housed. Delivery is via the perimeter slits that can be orientated with the remote control.

GLL20: Recovery and air supply grille in plastic, RAL 9010 colour, measuring 840x840; adapts perfectly to standard false ceilings without overlapping parts. Intake is in the central part, where the easily removable air filter is housed. Delivery is via the perimeter slits that can be manually orientated. Must be combined with a wall-mounted panel.

GLL20N: Recovery and air supply grille in plastic, RAL 9010 colour, measuring 840x840; adapts perfectly to standard false ceilings without overlapping parts. Fitted with a thermostat board that necessarily requires the installation of the VMF-E4X panel as well, and suitable for use with the RXLE heater. Intake is in the central part, where the easily removable air filter is housed. Delivery is via the perimeter slits that can be orientated with the remote control.

GLL20R: Recovery and air supply grille in plastic, RAL 9010 colour, measuring 840x840; adapts perfectly to standard false ceilings without overlapping parts. Fitted with an infrared receiver with an emergency operation button, and a remote control. Suitable for use with the RXLE heater. Intake is in the central part, where the easily removable air filter is housed. Delivery is via the perimeter slits that can be orientated with the remote control.

VMF system

VMF-E4DX: Wall-mounted user interface. Grey front panel PANTONE 425C (METAL).

VMF-E4X: Wall-mounted user interface. Light grey front panel PANTONE COOL GRAY 1C.

VMF-IO: Expansion board that extends the availability of digital inputs and outputs (configured via the dip switches).

VMF-IR: User interface, only available in combination with the GLF M or GLFI M grille and supplied in the form of an infrared remote control.

VMF-SW1: Extra water probe to be used for 4-pipe systems.

Control panels and their accessories

AER503: Wall-mounted panel.

FMT10: Electronic thermostat for fan coil in to 2/4 pipe systems.

PX2: Commutator switch.

PX2C6: Commutator switch. Kit to 6 pz.

PXAE: Electronic thermostat with thermostated or continuous ventilation.

SIT3: Thermostat Interface Card allowing the creation of a network of fan coils (max. 10) commanded by a central control panel (selector or thermostat). Commands the 3 fan speeds and must be installed on each fan coil within the network; receives the commands from the selector or the SIT5 card.

SIT5: Thermostat Interface Card allowing the creation of a network of fan coils (max. 10) commanded by a central control panel (selector or thermostat). Commands the 3 fan speeds and up to 2 valves (four pipe systems); sends the thermostat's commands to the fan coil network.

SW3: Water temperature probe. Allows automatic season change on electronic controllers supplied with water-side change over.

SW4: Water temperature probe allowing automatic season change on electronic controllers supplied with water-side change over.

SWA: External probe accessory SWA (length L = 6m). It detects the temperature of the room air if connected to the connector (A) of the FMT21 panel. The room air temperature probe, incorporated in the panel, is automatically disabled. It detects the temperature of the water in the system for ventilation consent if connected to the connector (W) of the FMT21 panel. Two SWA probes can be connected simultaneously to the FMT21 panel.

TPF: Electronic thermostat, black, with thermostated or continuous ventilation.

TPFW: Electronic thermostat, white, with thermostated or continuous ventilation.

TX: Electronic control panel.

WMT10: Electronic thermostat, white, with thermostated or continuous ventilation.

Electric heaters

RXLE: Electric heater for heating, can be installed on board the units.

RXLE20: Electric heater for heating, can be installed on board the units.

Water valve kit

VCFLX4: 3-way valve kit for single-coil fan coil for 4-pipe systems. With totally separate "heating" and "cooling" circuits. This kit consists of two 3-way insulated valves and four connections, complete with electro-thermal actuators, insulating shells for the valves, and the relative hydraulic couplings.

VHL1: 3-way motorised valve kit with 4 connections including the actuator. 230V~50Hz power supply.

VHL124: 3-way motorised valve kit with 4 connections including the actuator. 24V power supply.

VHL20: Motorised 3-way valve kit with 4 connections, complete with actuator and the relative hydraulic couplings. 230V~50Hz power supply.

VHL2024: Motorised 3-way valve kit with 4 connections, complete with actuator and the relative hydraulic couplings. 24V power supply.

VHL2: 2-way motorised valve kit with 2 connections including the actuator. Power supply 230V~50Hz;

VHL22: Motorised 2-way valve kit with 2 connections, complete with actuator and the relative hydraulic couplings. Power supply 230V~50Hz;

VHL2224: Motorised 2-way valve kit with 2 connections, complete with actuator and the relative hydraulic couplings. 24V power supply.

VHL224: 2-way motorised valve kit with 2 connections including the actuator. 24V power supply.

Installation accessories

FEL10: Kit n°5 electrostatically pre-charged air filter, with fire resistance class 2 (UL 900).

KFL: Delivery flange, allowing the air to be directed to an adjacent room.

KFL20: Delivery flange, allowing the air to be directed to an adjacent room. Up to three KFL20 can be assembled on a single unit.

KFLD: Suction flange, allows to introduce external air directly into the room without mixing.

KFLD20: Suction flange, allows to introduce external air directly into the room without mixing. Up to two KFLD20 can be assembled on a single unit.

FCLMC10: Perimeter housing in painted galvanised sheet metal, 600x600, used when the fan coil is installed outside the false ceiling. It has an aesthetic and protective purpose only, so the technical characteristics of the fan coil remain unaltered. Can only be combined with GLL/GLLI grilles.

FCLMC20: Perimeter housing in painted sheet metal, 840x840, used when the fan coil is installed outside the false ceiling. It has an aesthetic and protective purpose only, so the technical characteristics of the fan coil remain unaltered. Can only be combined with GLL/GLLI grilles.

Accessories that can be combined with the grilles

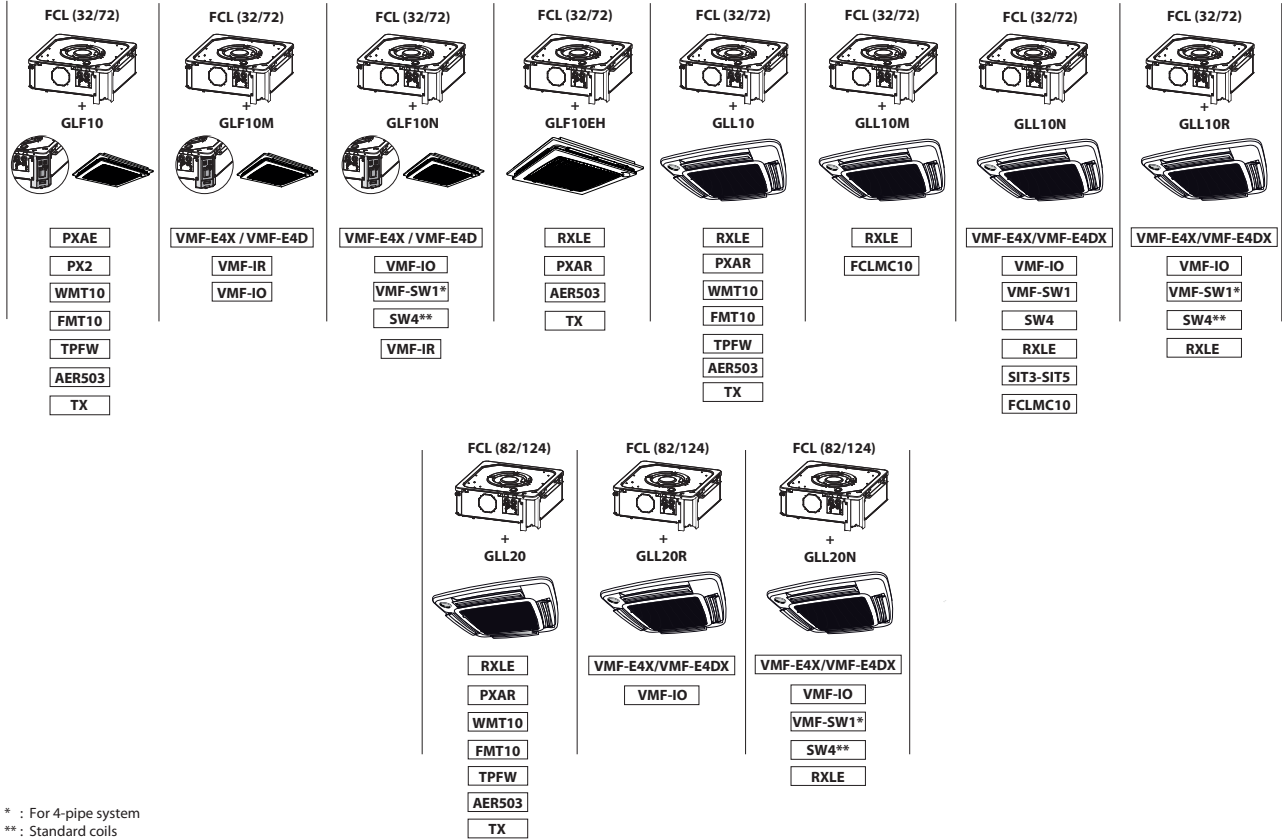

ACCESSORIES COMPATIBILITY

Intake grids and distribution of the air

Model	Ver	32	34	36	38	42	44	62	64
GLF10 (1)	FCL,V2,VL
GLF10EH (2)	FCL,V2,VL
GLF10M (3)	FCL,V2,VL
GLF10N (3)	FCL,V2,VL

Model	Ver	72	82	84	102	104	122	124
GLF10 (1)	FCL,V2,VL	.						
GLF10EH (2)	FCL,V2,VL	.						
GLF10M (3)	FCL,V2,VL	.						
GLF10N (3)	FCL,V2,VL	.						

- (1) Not compatible with the VMF system and electric heaters.
- (2) Not compatible with the VMF system.
- (3) Compatible with the VMF system and electric heaters.

Intake grid and distribution of the air

Model	Ver	32	34	36	38	42	44	62	64
GLL10 (1)	FCL,V2,VL
GLL10M (2)	FCL,V2,VL
GLL10N (3)	FCL,V2,VL
GLL10R (4)	FCL,V2,VL

Model	Ver	72	82	84	102	104	122	124
GLL10 (1)	FCL,V2,VL	.						
GLL10M (2)	FCL,V2,VL	.						
GLL10N (3)	FCL,V2,VL	.						

Model	Ver	72	82	84	102	104	122	124
GLL10R (4)	FCL,V2,VL	*						
GLL20 (1)	FCL,V2,VL		*	*	*	*	*	*
GLL20N (3)	FCL,V2,VL		*	*	*	*	*	*
GLL20R (4)	FCL,V2,VL		*	*	*	*	*	*

- (1) Not compatible with the VMF system and electric heaters.
(2) Not compatible with the VMF system, but compatible with electric heaters.
(3) Compatible with the VMF system.
(4) Not compatible with the VMF system.

VMF system

Model	Ver	32	34	36	38	42	44	62	64
VMF-E4DX	FCL,V2,VL	*	*	*	*	*	*	*	*
VMF-E4X	FCL,V2,VL	*	*	*	*	*	*	*	*
VMF-IO	FCL,V2,VL	*	*	*	*	*	*	*	*
VMF-IR	FCL,V2,VL	*	*	*	*	*	*	*	*
VMF-SW1	FCL,V2,VL	*	*	*	*	*	*	*	*

Model	Ver	72	82	84	102	104	122	124
VMF-E4DX	FCL,V2,VL	*	*	*	*	*	*	*
VMF-E4X	FCL,V2,VL	*	*	*	*	*	*	*
VMF-IO	FCL,V2,VL	*	*	*	*	*	*	*
VMF-IR	FCL,V2,VL	*	*	*	*	*	*	*
VMF-SW1	FCL,V2,VL	*	*	*	*	*	*	*

Control panels and dedicated accessories

Model	Ver	32	34	36	38	42	44	62	64
AER503	FCL,V2,VL	*	*	*	*	*	*	*	*
FMT10	FCL,V2,VL	*	*	*	*	*	*	*	*
PX2	FCL,V2,VL	*	*	*	*	*	*	*	*
PX2C6 (1)	FCL,V2,VL	*	*	*	*	*	*	*	*
PXAE	FCL,V2,VL	*	*	*	*	*	*	*	*
SIT3 (2)	FCL,V2,VL	*	*	*	*	*	*	*	*
SIT5 (2)	FCL,V2,VL	*	*	*	*	*	*	*	*
SW3 (3)	FCL,V2,VL	*	*	*	*	*	*	*	*
SW4	FCL,V2,VL	*	*	*	*	*	*	*	*
SWA	FCL,V2,VL	*	*	*	*	*	*	*	*
TPF	FCL,V2,VL	*	*	*	*	*	*	*	*
TPFW	FCL,V2,VL	*	*	*	*	*	*	*	*
TX (4)	FCL,V2,VL	*	*	*	*	*	*	*	*
WMT10	FCL,V2,VL	*	*	*	*	*	*	*	*

Model	Ver	72	82	84	102	104	122	124
AER503	FCL,V2,VL	*	*	*	*	*	*	*
FMT10	FCL,V2,VL	*	*	*	*	*	*	*
PX2	FCL,V2,VL	*	*	*	*	*	*	*
PX2C6 (1)	FCL,V2,VL	*	*	*	*	*	*	*
PXAE	FCL,V2,VL	*	*	*	*	*	*	*
SIT3 (2)	FCL,V2,VL	*	*	*	*	*	*	*
SIT5 (2)	FCL,V2,VL	*	*	*	*	*	*	*
SW3 (3)	FCL,V2,VL	*	*	*	*	*	*	*
SW4	FCL,V2,VL	*	*	*	*	*	*	*
SWA	FCL,V2,VL	*	*	*	*	*	*	*
TPF	FCL,V2,VL	*	*	*	*	*	*	*
TPFW	FCL,V2,VL	*	*	*	*	*	*	*
TX (4)	FCL,V2,VL	*	*	*	*	*	*	*
WMT10	FCL,V2,VL	*	*	*	*	*	*	*

- (1) Only wall-mount installation
(2) Cards for PXAE-PXAR-AER503-TX thermostats if present.
(3) Cards for PXAE-PXAR-AER503-TX thermostats if present.
(4) Wall-mount installation.

For the compatibility of VMF components and command panels with the intake and delivery grilles, refer to the information given above.

3 way valve kit

Model	Ver	32	34	36	38	42	44	62	64
VHL1 (1)	VL		*		*		*		*
VHL124 (1)	VL		*		*		*		*

Model	Ver	72	82	84	102	104	122	124
VHL20 (1)	VL			*		*		*
VHL2024 (1)	VL			*		*		*

- (1) Obligatory accessory in 4-pipe systems.

2 way valve kit

Model	Ver	32	34	36	38	42	44	62	64
VHL2 (1)	VL	
VHL224 (1)	VL	

Model	Ver	72	82	84	102	104	122	124
VHL22 (1)	VL			.		.		.
VHL2224 (1)	VL			.		.		.

(1) Compulsory accessory in 4-pipe systems with variable flow rate.

Valve Kit for 4 pipe systems

Model	Ver	32	34	36	38	42	44	62	64
VCFLX4 (1)	VL	

Model	Ver	72	82	84	102	104	122	124
VCFLX4 (1)	VL	.						

(1) The valve must be commanded via command panels enabled for valve control.

Air filters

Model	Ver	32	34	36	38	42	44	62	64
FEL10	FCL,V2,VL

Model	Ver	72	82	84	102	104	122	124
FEL10	FCL,V2,VL	.						

Delivery flange

Model	Ver	32	34	36	38	42	44	62	64
KFL	FCL,V2,VL
KFLD	FCL,V2,VL

Model	Ver	72	82	84	102	104	122	124
KFL	FCL,V2,VL	.						
KFL20	FCL,V2,VL	
KFLD	FCL,V2,VL	.						
KFLD20	FCL,V2,VL	

Perimeter case

Model	Ver	32	34	36	38	42	44	62	64
FCLMC10 (1)	FCL,V2,VL

Model	Ver	72	82	84	102	104	122	124
FCLMC10 (1)	FCL,V2,VL	.						
FCLMC20 (1)	FCL,V2,VL	

(1) Can only be combined with GLL/GLLI grilles

DIMENSIONS

Dimensions FCL 32 - 34 - 36 - 38 - 42 - 44 - 64 - 72 con GLF

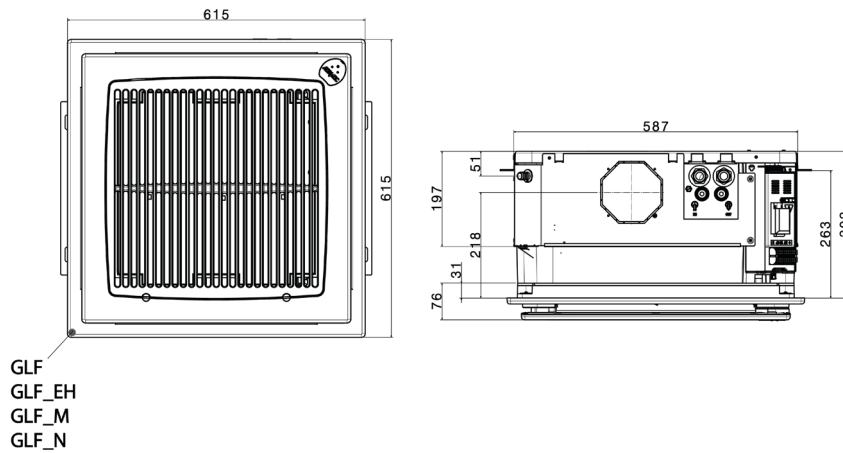

Dimensions FCL 32 - 34 - 36 - 38 - 42 - 44 - 64 - 72 con GLL

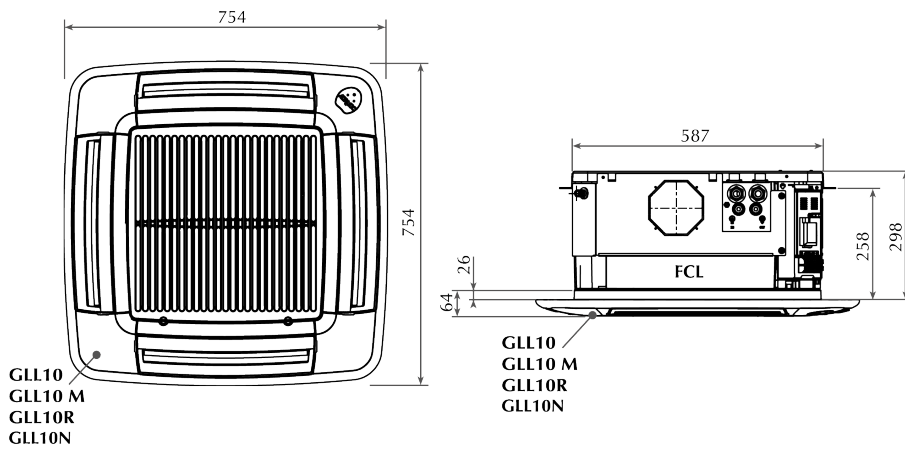

Dimensions FCL 82 - 84 - 102 - 104 - 122 - 124 con GLL

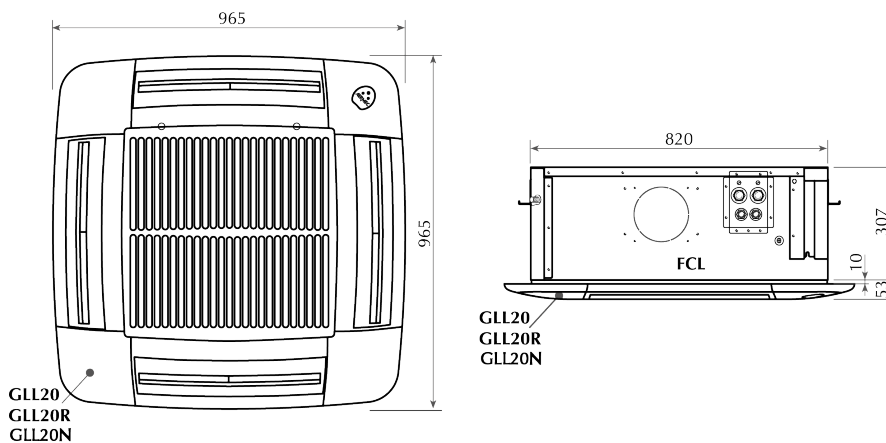

Size		102	104	122	124	32	34	36	38	42	44	62	64	72	82	84
Dimensions and weights																
	FCL	kg	36	36	36	36	20	21	20	21	21	22	22	22	35	36
Weight empty	V2	kg	36	36	36	36	20	21	20	21	21	21	22	22	35	36
	VL	kg	35	35	35	35	20	20	20	20	20	22	22	22	34	35

Aermec reserves the right to make any modifications deemed necessary.
All data is subject to change without notice. Aermec does not assume responsibility or liability for errors or omissions.

Aermec S.p.A.

Via Roma, 996 - 37040 Bevilacqua (VR) - Italia
Tel. 0442633111 - Telefax 044293577
www.aermec.com