

# ANL 021-202

## Air-water chiller

Cooling capacity 5,7 ÷ 43,3 kW



- **Standard version**
- **Version with Integrated hydronic kit system side**



### DESCRIPTION

Chillers for external installation for chilled water production with scroll compressors, axial fans, external copper coils with aluminum louvers from size 020 to 090, microchannel from size 102 to 202. The base, the structure and the panels are made of steel treated with polyester paint RAL 9003.

### VERSIONS

- ° Standard
- A** With storage tank and pump
- N** With increased pump
- P** With pump
- Q** With storage tank and increased pump

### FEATURES

#### Operating field

Operation at full load up to 46°C external air temperature. Unit can produce chilled water up to -10°C.

#### Version with Integrated hydronic kit

Integrated hydronic kit containing the main hydraulic components; available with various configurations to obtain a solution that allows you to facilitate installation.

#### Hot water production

In the configuration with desuperheater, it is also possible to produce free-hot water.

#### Double mechanical thermostat

On the configurator it is also possible to select the option "W" double mechanical thermostatic valve for low temperatures.

**Using two electronic valves in parallel guarantees a precise and efficient control in a wide operating range. This allows them to produce chilled water from -10 °C to +18 °C.**

■ *The option is only available for sizes from 050 to 090 in the °A-Q versions and from size 102 to 202 in all versions.*

### MODUCONTROL CONTROL

The command panel of the unit allows the rapid setting of the working parameters of the machine, and their visualisation. The display consists of 4 figures and various LEDs for indicating the type of operational mode, the visualisation of the parameters set and of any alarms triggered. The card stores all the default settings and any modifications.

### ACCESSORIES

**AERLINK:** Wifi Gateway with an RS485 serial port that can be installed on all machines or on all controllers having an RS485 serial port themselves. The module is capable of simultaneously activating the AP WIFI (Access point) and WIFI Station functions, the latter making it possible to connect to the home or business LAN both with VMF-E5 and E6. To facilitate certain management and control operations of the unit, the AERAPP application is available both for Android and iOS systems.

**MODU-485BL:** RS-485 interface for supervision systems with MODBUS protocol.

**MULTICONTROL:** Allows the simultaneous control of several units (up to 4), installed in the same hydraulic system.

**PR3:** Simplified remote panel. This makes it possible to carry out the unit's basic controls with the signalling of alarms. Can be made remote with shielded cable up to 150 m.

**SPLW:** System water temperature sensor. In most cases the loose supplied sensors for each chiller/heat pump are sufficient. In cases of a common flow/return header this sensor can be used to control the common system supply water temperature for the chillers connected to the header, or it can be used for temperature monitoring

**VMF-CRP:** Accessory module for controlling boilers, heat recover units and pumps (if associated with VMF-E5 / RCC panels); if associated with the VMF-E6 panel, the VMF-CRP modules will be able to manage heat recovery units, RAS, boiler, sanitary management, I/O control, pumps.

**DCPX:** Device for condensation temperature control, with continuous speed modulation of fans by using a pressure transducer.

**VT:** Antivibration supports

## FACTORY FITTED ACCESSORIES

**DRE:** Electronic device for peak current reduction.

**RA:** Anti-freeze electric heater for the buffer tank.

**KR:** Anti-freeze electric heater for the plate heat exchanger.

## COMPATIBILITY WITH VMF SYSTEM

For more information about VMF system, refer to the dedicated documentation.

## ACCESSORIES COMPATIBILITY

### Accessories

Model	Ver	021	026	031	041	050	070	080	090	102	152	202
AERLINK	°A,P	*	*	*	*	*	*	*	*	*	*	*
	N									*	*	*
	Q					*	*	*	*	*	*	*
MODU-485BL	°A,P	*	*	*	*	*	*	*	*	*	*	*
	N									*	*	*
	Q					*	*	*	*	*	*	*
MULTICONTROL	°A,P	*	*	*	*	*	*	*	*	*	*	*
	N									*	*	*
	Q					*	*	*	*	*	*	*
PR3	°A,P	*	*	*	*	*	*	*	*	*	*	*
	N									*	*	*
	Q					*	*	*	*	*	*	*
SPLW (1)	°A,P	*	*	*	*	*	*	*	*	*	*	*
	N									*	*	*
	Q					*	*	*	*	*	*	*
VMF-CRP	°A,P	*	*	*	*	*	*	*	*	*	*	*
	N									*	*	*
	Q					*	*	*	*	*	*	*

(1) Probe required for MULTICONTROL to manage the secondary circuit system.

### DCPX: Condensation control temperature

Ver	021	026	031	041	050	070	080	090	102	152	202
°A,P	DCPX50	DCPX50	DCPX50	DCPX50	DCPX50	DCPX50	DCPX50	DCPX50	DCPX52	DCPX52	DCPX52
N	-	-	-	-	-	-	-	-	DCPX52	DCPX52	DCPX52
Q	-	-	-	-	DCPX50	DCPX50	DCPX50	DCPX50	DCPX52	DCPX52	DCPX52

### VT: Antivibration

Ver	021	026	031	041	050	070	080	090	102	152	202
°P	VT9	VT9	VT9	VT9	VT9	VT9	VT9	VT9	VT15	VT15	VT15
A	VT9	VT9	VT9	VT9	VT15	VT15	VT15	VT15	VT15	VT15	VT15
N	-	-	-	-	-	-	-	-	VT15	VT15	VT15
Q	-	-	-	-	VT15	VT15	VT15	VT15	VT15	VT15	VT15

### DRE: Device for peak current reduction

Ver	050	070	080	090	102	152	202
Power supply: °							
°A,PQ	DRES (1)	DRES (1)	DRES (1)	DRES (1)	DRES x 2 (1)	DRES x 2 (1)	DRES x 2 (1)
N	-	-	-	-	DRES x 2 (1)	DRES x 2 (1)	DRES x 2 (1)

(1) Only for supplies of 400V 3N ~ 50Hz and 400V 3 ~ 50Hz. x 2 or x 3 (if present) indicates the quantity to be ordered.  
A grey background indicates the accessory must be assembled in the factory

### KR: electric heater for the plate heat exchanger

Ver	021	026	031	041	050	070	080	090	102	152	202
°P	KR2	KR2	KR2	KR2	KR2	KR2	KR2	KR2	KR100	KR100	KR100
A,Q	-	-	-	-	KR2	KR2	KR2	KR2	KR100	KR100	KR100
N	-	-	-	-	-	-	-	-	KR100	KR100	KR100

A grey background indicates the accessory must be assembled in the factory

### RA: electric heater for the buffer tank

Ver	021	026	031	041	050	070	080	090	102	152	202
A	RA	RA	RA	RA	RA	RA	RA	RA	RA100	RA100	RA100
Q	-	-	-	-	RA	RA	RA	RA	RA100	RA100	RA100

A grey background indicates the accessory must be assembled in the factory

## CONFIGURATOR

Field	Description
<b>1,2,3</b>	<b>ANL</b>
<b>4,5,6</b>	<b>Size</b> 021, 026, 031, 041, 050, 070, 080, 090, 102, 152, 202
<b>7</b>	<b>Model</b>
°	Cooling only
<b>8</b>	<b>Version</b>
°	Standard
A	With storage tank and pump
N	With increased pump (1)
P	With pump
Q	With storage tank and increased pump (2)
<b>9</b>	<b>Heat recovery</b>
°	Without heat recovery
D	With desuperheater (3)
<b>10</b>	<b>Coils</b>
°	Copper-aluminium (4)
R	Copper pipes-copper fins
S	Copper pipes-Tinned copper fins
V	Copper pipes-Coated aluminium fins
<b>11</b>	<b>Operating field</b>
°	Standard mechanic thermostatic valve (5)
W	Double mechanic thermostat for low temperature (6)
Y	Low temperature mechanic thermostatic valve (7)
Z	Low temperatures mechanic thermostatic valve (8)
<b>12</b>	<b>Evaporator</b>
°	Standard
<b>13</b>	<b>Power supply</b>
°	400V 3N ~ 50Hz (9)
M	230V ~ 50Hz (10)

(1) Only for ANL 102 ÷ 202 sizes

(2) Only for ANL 050 ÷ 202 sizes

(3) If the unit is also fitted with one of the low temperature valves in addition to the desuperheater, it is necessary to always guarantee a water temperature of 35°C at the inlet of the heat exchanger. The desuperheater is only available in sizes from 050 to 090 in the version with storage tank "A", and from size 102 to 202 in all versions.

(4) Sizes from 102 to 202 have a micro-channel coil

(5) Water produced up to +4 °C

(6) Water produced from -10 °C to 18 °C; Option available only for sizes starting from 050 to 090 in the "A-Q versions and from 102 to 202 in all versions

(7) Water produced from 0 °C up to -10 °C

(8) Water produced from +4 °C up to +0 °C

(9) For all sizes

(10) Only for ANL 021 ÷ 041 sizes

## PERFORMANCE SPECIFICATIONS

### ANL - ° (400V 3N ~ 50Hz / 230V ~ 50Hz)

Size		021	026	031	041	050	070	080	090	102	152	202
<b>Power supply: °</b>												
<b>Cooling performance 12 °C / 7 °C (1)</b>												
Cooling capacity	kW	5,7	6,2	7,5	9,6	13,4	16,4	20,4	22,2	26,5	32,9	42,8
Input power	kW	1,9	2,0	2,5	3,3	4,1	4,9	6,4	6,8	8,0	10,2	13,5
Cooling total input current	A	3,7	4,2	4,7	6,2	8,7	9,7	12,0	13,0	16,0	19,0	25,0
EER	W/W	3,03	3,04	2,99	2,90	3,26	3,33	3,18	3,28	3,32	3,21	3,18
Water flow rate system side	l/h	979	1065	1289	1649	2302	2835	3522	3831	4570	5670	7388
Pressure drop system side	kPa	21	21	22	24	30	30	36	50	58	61	68
<b>Power supply: M</b>												
<b>Cooling performance 12 °C / 7 °C (1)</b>												
Cooling capacity	kW	5,7	6,2	7,5	9,6	-	-	-	-	-	-	-
Input power	kW	1,9	2,0	2,5	3,3	-	-	-	-	-	-	-
Cooling total input current	A	6,4	7,3	8,2	11,0	-	-	-	-	-	-	-
EER	W/W	3,03	3,04	2,99	2,90	-	-	-	-	-	-	-
Water flow rate system side	l/h	979	1065	1289	1649	-	-	-	-	-	-	-
Pressure drop system side	kPa	21	21	22	24	-	-	-	-	-	-	-

(1) Data EN 14511:2022; Heat exchanger water (services side) 12°C / 7°C; outside air 35°C

**ANL - P (400V 3N ~ 50Hz / 230V ~ 50Hz)**

Size		021	026	031	041	050	070	080	090	102	152	202
<b>Power supply: °</b>												
<b>Cooling performance 12 °C / 7 °C (1)</b>												
Cooling capacity	kW	5,7	6,2	7,6	9,7	13,5	16,6	20,6	22,4	26,8	33,2	43,2
Input power	kW	1,8	2,0	2,5	3,2	4,1	4,9	6,4	6,7	8,1	10,5	13,8
Cooling total input current	A	4,0	4,5	5,0	6,6	9,3	10,0	13,0	13,0	17,0	21,0	27,0
EER	W/W	3,11	3,12	3,07	2,97	3,31	3,38	3,23	3,35	3,32	3,15	3,13
Water flow rate system side	l/h	979	1065	1289	1649	2302	2835	3522	3831	4570	5670	7388
Useful head system side	kPa	73,0	73,0	71,0	65,0	76,0	72,0	57,0	52,0	84,0	115,0	90,0

**Power supply: M**

<b>Cooling performance 12 °C / 7 °C (1)</b>												
Cooling capacity	kW	5,7	6,2	7,6	9,7	-	-	-	-	-	-	-
Input power	kW	1,8	2,0	2,5	3,2	-	-	-	-	-	-	-
Cooling total input current	A	7,0	7,9	8,8	11,0	-	-	-	-	-	-	-
EER	W/W	3,11	3,12	3,07	2,97	-	-	-	-	-	-	-
Water flow rate system side	l/h	979	1065	1289	1649	-	-	-	-	-	-	-
Useful head system side	kPa	73,0	73,0	71,0	65,0	-	-	-	-	-	-	-

(1) Data EN 14511:2022; Heat exchanger water (services side) 12°C / 7°C; outside air 35°C

**ANL - N (400V 3N ~ 50Hz)**

Size		021	026	031	041	050	070	080	090	102	152	202
<b>Cooling performance 12 °C / 7 °C (1)</b>												
Cooling capacity	kW	-	-	-	-	-	-	-	-	26,8	33,3	43,3
Input power	kW	-	-	-	-	-	-	-	-	8,5	10,6	13,8
Cooling total input current	A	-	-	-	-	-	-	-	-	18,0	21,0	27,0
EER	W/W	-	-	-	-	-	-	-	-	3,17	3,15	3,13
Water flow rate system side	l/h	-	-	-	-	-	-	-	-	4570	5669	7387
Useful head system side	kPa	-	-	-	-	-	-	-	-	140,0	185,0	159,0

(1) Data EN 14511:2022; Heat exchanger water (services side) 12°C / 7°C; outside air 35°C

**ANL - A (400V 3N ~ 50Hz / 230V ~ 50Hz)**

Size		021	026	031	041	050	070	080	090	102	152	202
<b>Power supply: °</b>												
<b>Cooling performance 12 °C / 7 °C (1)</b>												
Cooling capacity	kW	5,7	6,2	7,6	9,7	13,5	16,6	20,6	22,4	26,8	33,2	43,2
Input power	kW	1,8	2,0	2,5	3,2	4,1	4,9	6,4	6,7	8,1	10,5	13,8
Cooling total input current	A	4,0	5,0	5,0	7,0	10,0	11,0	13,0	14,0	17,0	21,0	27,0
EER	W/W	3,11	3,12	3,07	2,97	3,31	3,38	3,23	3,35	3,32	3,15	3,13
Water flow rate system side	l/h	979	1065	1288	1649	2302	2834	3522	3831	4570	5669	7387
Useful head system side	kPa	73,0	73,0	71,0	65,0	76,0	72,0	57,0	52,0	84,0	115,0	91,0

**Power supply: M**

<b>Cooling performance 12 °C / 7 °C (1)</b>												
Cooling capacity	kW	5,7	6,2	7,6	9,7	-	-	-	-	-	-	-
Input power	kW	1,8	2,0	2,5	3,2	-	-	-	-	-	-	-
Cooling total input current	A	7,0	7,9	8,8	11,0	-	-	-	-	-	-	-
EER	W/W	3,11	3,12	3,07	2,97	-	-	-	-	-	-	-
Water flow rate system side	l/h	979	1065	1289	1649	-	-	-	-	-	-	-
Useful head system side	kPa	73,0	73,0	71,0	65,0	-	-	-	-	-	-	-

(1) Data EN 14511:2022; Heat exchanger water (services side) 12°C / 7°C; outside air 35°C

**ANL - Q (400V 3N ~ 50Hz)**

Size		021	026	031	041	050	070	080	090	102	152	202
<b>Cooling performance 12 °C / 7 °C (1)</b>												
Cooling capacity	kW	-	-	-	-	13,6	16,7	20,7	22,5	26,8	33,3	43,3
Input power	kW	-	-	-	-	4,2	5,0	6,5	6,8	8,5	10,6	13,8
Cooling total input current	A	-	-	-	-	10,0	11,0	13,0	14,0	18,0	21,0	27,0
EER	W/W	-	-	-	-	3,24	3,33	3,19	3,31	3,17	3,15	3,13
Water flow rate system side	l/h	-	-	-	-	2302	2834	3522	3831	4570	5669	7387
Useful head system side	kPa	-	-	-	-	160,0	159,0	144,0	140,0	140,0	185,0	159,0

(1) Data EN 14511:2022; Heat exchanger water (services side) 12°C / 7°C; outside air 35°C

### ENERGY INDICES (REG. 2016/2281 EU)

Size		021	026	031	041	050	070	080	090	102	152	202	
<b>SEER - 12/7 (EN14825:2018) with standard fans (1)</b>													
SEER	°	W/W	- (2)	- (2)	- (2)	- (2)	- (2)	- (2)	- (2)	- (2)	- (2)	- (2)	
	A,P	W/W	4,18	4,20	4,17	4,10	4,16	4,34	4,19	4,31	4,11	4,10	
	N	W/W	-	-	-	-	-	-	-	-	- (2)	- (2)	
	Q	W/W	-	-	-	-	- (2)	- (2)	- (2)	- (2)	- (2)	- (2)	
Seasonal efficiency	°	%	- (2)	- (2)	- (2)	- (2)	- (2)	- (2)	- (2)	- (2)	- (2)	- (2)	
	A,P	%	164,00	164,80	163,60	161,00	163,40	170,70	164,60	169,40	161,30	161,10	
	N	%	-	-	-	-	-	-	-	-	- (2)	- (2)	
	Q	%	-	-	-	-	- (2)	- (2)	- (2)	- (2)	- (2)	- (2)	
<b>SEER - 23/18 (EN14825:2018) with standard fans (3)</b>													
SEER	°	W/W	4,34	4,35	4,31	4,21	4,55	4,68	4,49	4,61	4,83	4,73	4,69
	A,P	W/W	4,49	4,51	4,48	4,47	4,55	4,64	4,57	4,66	4,49	4,25	4,28
	N	W/W	-	-	-	-	-	-	-	-	4,15	4,18	4,23
	Q	W/W	-	-	-	-	4,18	4,44	4,35	4,49	4,15	4,18	4,23
Seasonal efficiency	°	%	170,40	170,90	169,20	165,20	179,10	184,30	176,60	181,50	190,30	186,00	184,70
	A,P	%	176,70	177,50	176,00	175,60	179,00	182,40	179,80	183,50	176,60	167,00	168,00
	N	%	-	-	-	-	-	-	-	-	163,10	164,20	166,00
	Q	%	-	-	-	-	164,30	174,50	171,10	176,70	163,10	164,20	166,00
<b>SEPR - (EN14825:2018) High temperature with standard fans (3)</b>													
SEPR	°	W/W	5,92	5,92	5,85	5,69	6,36	6,50	6,21	6,43	6,79	6,58	6,49
	A,P	W/W	6,56	6,57	6,45	6,21	6,74	6,90	6,55	6,78	6,68	6,18	6,17
	N	W/W	-	-	-	-	-	-	-	-	5,91	6,09	6,10
	Q	W/W	-	-	-	-	6,03	6,28	6,08	6,30	5,91	6,09	6,10

- (1) Calculation performed with FIXED water flow rate and VARIABLE outlet temperature.  
 (2) Non-compliant with 2016/2281 EU regulation for comfort applications 12°C / 7°C  
 (3) Calculation performed with FIXED water flow rate.

### ELECTRIC DATA

Size		021	026	031	041	050	070	080	090	102	152	202	
<b>Power supply: °</b>													
<b>Electric data</b>													
Maximum current (FLA)	°	A	5,0	6,0	6,0	9,0	11,0	14,0	16,0	17,0	22,0	26,0	32,0
	A,P	A	6,0	7,0	7,0	10,0	13,0	15,0	18,0	19,0	23,0	28,0	34,0
	N	A	-	-	-	-	-	-	-	-	24,0	28,0	34,0
	Q	A	-	-	-	-	12,0	14,0	17,0	18,0	24,0	28,0	34,0
Peak current (LRA)	°	A	28,0	38,0	39,0	44,0	65,0	75,0	102,0	96,0	76,0	87,0	117,0
	A,P	A	29,0	39,0	40,0	45,0	67,0	77,0	104,0	98,0	77,0	89,0	119,0
	N	A	-	-	-	-	-	-	-	-	78,0	89,0	119,0
	Q	A	-	-	-	-	66,0	76,0	103,0	97,0	78,0	89,0	119,0
<b>Power supply: M</b>													
<b>Electric data</b>													
Maximum current (FLA)	°	A	13,0	16,0	18,0	22,0	-	-	-	-	-	-	
	A,P	A	14,0	17,0	19,0	23,0	-	-	-	-	-	-	
	N,Q	A	-	-	-	-	-	-	-	-	-	-	
Peak current (LRA)	°	A	64,0	68,0	69,0	100,0	-	-	-	-	-	-	
	A,P	A	62,0	69,0	70,0	101,0	-	-	-	-	-	-	
	N,Q	A	-	-	-	-	-	-	-	-	-	-	

### GENERAL TECHNICAL DATA

		ANL021	ANL026	ANL031	ANL041	ANL050	ANL070	ANL080	ANL090	ANL102	ANL152	ANL202	
<b>Compressor</b>													
Type	type							Scroll					
Compressor regulation	Type							On-Off					
Number	no.	1	1	1	1	1	1	1	1	2	2	2	
Circuits	no.	1	1	1	1	1	1	1	1	1	1	1	
Refrigerant	type							R410A					
Refrigerant charge (1)	kg	1,2	1,2	1,2	1,3	2,8	2,8	3,0	3,9	5,9	5,9	5,9	
<b>System side heat exchanger</b>													
Type	type							Brazen plate					
Number	no.	1	1	1	1	1	1	1	1	1	1	1	
<b>System side hydraulic connections</b>													
Sizes (in/out)	Ø							1"1/4					
<b>Fan</b>													
Type	type							Axial					
Fan motor	type							Asynchronous with phase cut					
Number	no.	1	1	1	1	1	1	1	1	2	2	2	
Air flow rate	m <sup>3</sup> /h	2500	2500	3500	3500	7200	7200	7300	7200	14000	13500	13500	
<b>Sound data calculated in cooling mode (2)</b>													
Sound power level	dB(A)	61,0	61,0	68,0	68,0	69,0	69,0	69,0	68,0	76,0	77,0	78,0	

	ANL021	ANL026	ANL031	ANL041	ANL050	ANL070	ANL080	ANL090	ANL102	ANL152	ANL202
Sound pressure level (1 m)	29,8	29,8	36,8	36,8	37,6	37,6	37,6	36,6	44,5	45,5	46,5

(1) The load indicated in the table is an estimated and preliminary value. The final value of the refrigerant load is indicated on the unit's technical label. For further information contact the office.

(2) Sound power calculated on the basis of measurements made in accordance with UNI EN ISO 9614-2, as required for Eurovent certification. Sound pressure (cold functioning) measured in free field, 10m away from the unit external surface (in compliance with UNI EN ISO 3744).

## DIMENSIONS

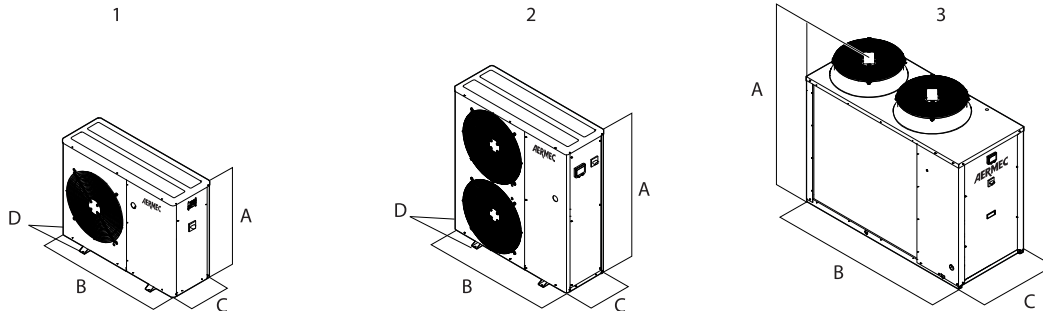

- 1 ANL 021-041
- 2 ANL 050-070
- 3 ANL 102-202

Size		021	026	031	041	050	070	080	090	102	152	202	
<b>Dimensions and weights</b>													
A	°P	mm	1000	1000	1000	1000	1252	1252	1252	1252	1450	1450	1450
	A	mm	1015	1015	1015	1015	1281	1281	1281	1281	1450	1450	1450
	N	mm	-	-	-	-	-	-	-	-	1450	1450	1450
	Q	mm	-	-	-	-	1281	1281	1281	1281	1450	1450	1450
B	°P	mm	900	900	900	900	1124	1124	1124	1124	1750	1750	1750
	A	mm	1124	1124	1124	1124	1165	1165	1165	1165	1750	1750	1750
	N	mm	-	-	-	-	-	-	-	-	1750	1750	1750
	Q	mm	-	-	-	-	1165	1165	1165	1165	1750	1750	1750
C	°P	mm	310	310	310	310	384	384	384	384	750	750	750
	A	mm	384	384	384	384	550	550	550	550	750	750	750
	N	mm	-	-	-	-	-	-	-	-	750	750	750
	Q	mm	-	-	-	-	550	550	550	550	750	750	750
D	°P	mm	354	354	354	354	428	428	428	428	-	-	-
	A	mm	428	428	428	428	-	-	-	-	-	-	-
	N	mm	-	-	-	-	-	-	-	-	-	-	-
	Q	mm	-	-	-	-	-	-	-	-	-	-	-
Empty weight	°	kg	86	86	86	86	120	120	120	156	270	293	329
	A	kg	103	103	103	103	147	147	147	183	338	364	400
	N	kg	-	-	-	-	-	-	-	-	338	364	400
	P	kg	91	91	91	91	127	127	163	163	288	314	350
	Q	kg	-	-	-	-	151	151	151	187	338	364	400

Aermec reserves the right to make any modifications deemed necessary.  
All data is subject to change without notice. Aermec does not assume responsibility or liability for errors or omissions.

### Aermec S.p.A.

Via Roma, 996 - 37040 Bevilacqua (VR) - Italia  
Tel. 0442633111 - Telefax 044293577  
www.aermec.com