

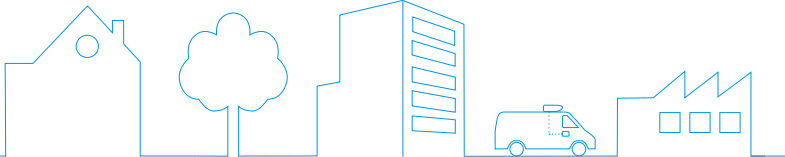

# Indoor air quality

for residential and  
light commercial  
applications



# Why Indoor Air Quality?

- Indoor Air Quality (IAQ) is a measure of the air quality indoors, as breathed in by the building's occupants.
- **Indoor air quality is often neglected** by residential buildings, schools, offices or light commercial buildings.
- The **indoor air quality can be 2 to 5 times worse than outdoors** because of pollutants such as pollen, bacteria and others.
- Since **90% of our lives is spent indoors**, it is crucial to invest in good air quality.

## 5 components

for ensuring good Indoor Air Quality

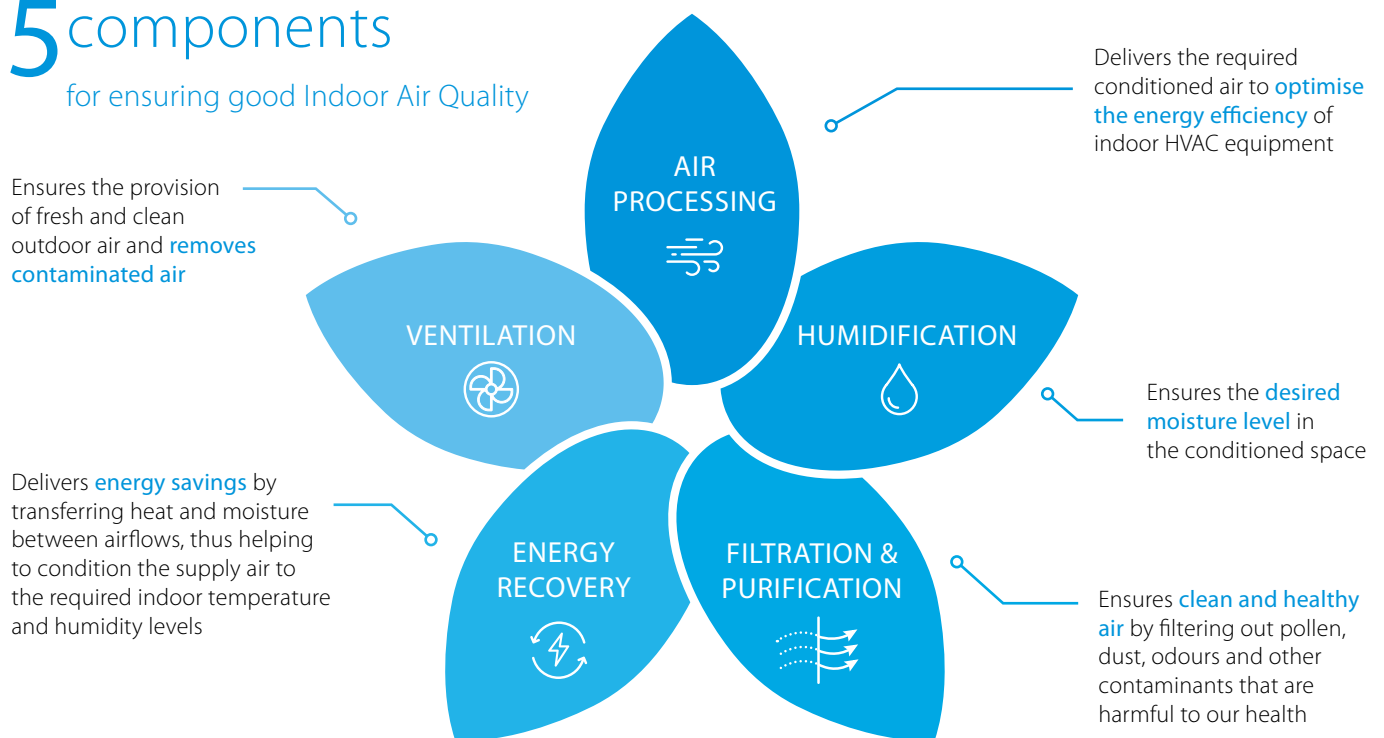

## Ventilation



## Filtration & air purification



A combination of ventilation & air purification processes help you in achieving a better indoor living condition for a healthier living.



# Indoor air quality for residential and light commercial applications

## Residential & light commercial

### air purification 18

Air Purifier Portfolio	18
Certification & Testing	20
<b>NEW</b> Onecta App Integration	22
Our Technology	24
<b>NEW</b> MCK70ZW/BFW & MCK70ZH/BFH	26
<b>NEW</b> MC80Z/ZB	27
MC30YV/YB	28
MC55W/VB	29
MCK55W	30
MCK70YV/YB	31

### Residential ventilation 32

Why DUCO	33
DUCO Portfolio at Daikin	34
On-demand Ventilation	35
DucoBox Energy Comfort	36
Technical specifications	38
Dimensions	40
<b>NEW</b> DucoBox Energy Comfort Plus	42
Technical specifications	44
Dimensions	46
DucoBox Energy Premium	48
Technical specifications	50
Dimensions	52
Total Ventilation Package	53
Material list	56



**NEW** MC80Z/ZB



**NEW** MCK70ZH/BFH



**NEW** DUCOBOX ENERGY COMFORT PLUS



Pure air  
because we care

## Breathe healthy and humidified air with Daikin Air Purifier

We offer a wide range of air purifiers with and without humidifiers, in all sorts of different sizes and applications. Whether you need a small air purifier for a single room or a larger one to cover a larger surface area, we have the perfect solution for you.

### MC80Z



- Air flow up to **480 m<sup>3</sup>/h**
- Air purification up to **124 m<sup>2</sup>**
- Intelligent** air purification
- Absorbs odour via **deodorising filter**
- High Performing Electrostatic **HEPA filter**

### MC55W



- Air flow up to **330 m<sup>3</sup>/h**
- Air purification up to **82 m<sup>2</sup>**
- Absorbs odour via **deodorising filter**
- High Performing Electrostatic **HEPA filter**

### MC30YV



- Air flow up to **180 m<sup>3</sup>/h**
- Air purification up to **46 m<sup>2</sup>**
- Absorbs odour via **deodorising filter**
- High Performing Electrostatic **HEPA filter**

## Air Purifier with humidifier

These units come with humidification function to increase the moisture in the air so that owners will be able to prevent dry air in winter or it can help the ones who easily suffer from soar throat.

### MCK70Z



- Air flow up to **420 m<sup>3</sup>/h**
- Air purification up to **96 m<sup>2</sup>**
- 650 ml/h** humidifying capacity
- Intelligent** air purification
- Absorbs odour via **deodorising filter**
- High Performing Electrostatic **HEPA filter**

### MCK55W



- Air flow up to **330 m<sup>3</sup>/h**
- Air purification up to **82 m<sup>2</sup>**
- 500 ml/h** humidifying capacity
- Absorbs odour via **deodorising filter**
- High Performing Electrostatic **HEPA filter**

### MCK70Y



- Air flow up to **420 m<sup>3</sup>/h**
- Air purification up to **96 m<sup>2</sup>**
- 650 ml/h** humidifying capacity
- Absorbs odour via **deodorising filter**
- High Performing Electrostatic **HEPA filter**



# What makes Daikin Air Purifier unique?

## Supreme Technology

Our air purifiers are designed with minimalistic style in mind, so they won't detract from the aesthetics of your home. The sleek, modern design is sure to complement any décor, while the lightweight construction makes them easy to move around.



Featuring clear indication lights that show you the current PM2.5 indication and there is also an easy-to-use control panel with all the settings you need.

Our air purifiers are also designed to be quiet, with low noise levels and minimal disruption.



## There when you need it

Our air purifiers are designed to keep your air clean and comfortable all year round.

## Daikin Streamer Technology

Our Daikin Air Purifiers are all equipped with our patented Daikin Streamer technology to decompose, by oxidation, harmful substances caught on the filter and ensuring it's market leading filter lifetime of ten years



## Peace of mind thanks to filter lifetime

A USP that makes our Daikin Air Purifiers unique.

The filters of our air purifiers lasts much longer than market standard, and ensures you of 10 years without renewing the filter.

This saves you costs and ensures you peace of mind for a 10 years period.

# Our Certificates\*\*

\*\* for a complete overview on which units have been tested, please refer to respective product pages. Please also refer to our online website for up to date information on certificates.

## Efficient against allergens as recognized by BAF (British Allergy Foundation)

The Allergy UK Seal of Approval reassures that the product is efficient at reducing small particulates which may include allergens, bacteria and viruses.



## Approved allergy-friendly quality of this product/service is certified by the European Centre for Allergy Research Foundation

An independent advisory panel of 15 leading international scientists and technicians has developed the criteria ECARF used to evaluate different product groups. They include threshold values and exclusion criteria that make an allergic reaction very unlikely. The criteria are regularly updated to reflect the latest scientific findings.

A product receives the Seal when it can be proved through audits or studies that the criteria have been fulfilled. The Daikin Air Purifiers passed these tests and can be considered as allergy-friendly. Not applicable on Air Purifiers with Humidifying function.



## Proven effectiveness against respiratory viruses (among others human coronavirus HCoV-229E) evaluated by Institut Pasteur de Lille\*

The units have also been evaluated as 99.93% effective against the H1N1 virus in 2.5 minutes\*. H1N1 is the virus causing common flu. This means Daikin's air purifiers are an additional measure in the fight against respiratory diseases. Our compact plug-and-play purifiers, whose effectiveness is achieved through a combination of the high performance electrostatic HEPA filter, which traps the virus, followed by an intense exposure to Daikin's patented Flash Streamer technology, which removes the virus, can strongly contribute to reducing the risk of respiratory virus transmission.



# 99.98%

of **coronavirus** removed in **2.5 minutes**

According to tests performed in the laboratories of the Institut Pasteur de Lille, Daikin's air purifiers remove more than 99.98% the human coronavirus HCoV-229E in 2.5 minutes\*. This virus is of the same family as SARS-CoV-2, the coronavirus behind the COVID-19 pandemic.

Discover more







# Our Partnership with Institut Pasteur de Lille



## What is Institut Pasteur de Lille?

- › The Institut Pasteur de Lille is a research foundation, which was founded in 1894. Created to respond to the epidemics of the 19th century, the Institut Pasteur de Lille has been fighting diseases for more than 120 years through research on pathogens, the development of vaccines and drugs and the promotion of preventive measures and good hygiene practices. The Institut Pasteur de Lille is a member of the international network of institutes Pasteur. Present in 25 countries on all continents, the Network brings together 32 institutions united by common missions and values for the benefit of populations. The mission is to put science at the service of health. Today, the Pasteur Institute of Lille has 33 research teams, more than 800 persons, working every day to understand and fight against diseases, to slow down their development and to imagine the treatments of tomorrow.

## What does this mean for our Air Purifiers?

- › As a specialist in air quality management, Daikin sees it as its mission to provide innovative solutions and has been selling air purifiers for over 45 years. Its air purifiers and patented air purifying technology, which is applied in other Daikin equipment, have long since proven their effectiveness against air pollution, as well as seasonal pollen and viruses. To reinforce the claim of the effectiveness of its technology, Daikin Europe N.V. entrusted the Institut Pasteur de Lille with the testing of its range of air purifiers. It has now been formally proven that the Daikin models remove more than 99.98% of the human coronavirus HCoV-229E in 2.5 minutes. This is an important achievement.

\*Daikin device MCK55WWM (commercial name MCK55W), tested by Institut Pasteur de Lille, removes 99.996 % of Human Coronavirus HCoV-229E in 2.5 minutes running time at 'turbo' speed in laboratory conditions (air-tight chamber with inner volume 0.47 m<sup>3</sup>, no air renewal). Human Coronavirus HCoV-229E is different from the virus responsible for COVID-19, SARS-CoV-2, but belongs to the same family of coronaviruses. | Daikin device MC55WWM (commercial names MC55W/VB), tested by Institut Pasteur de Lille, removes 99.98 % of Human Coronavirus HCoV-229E in 2.5 minutes running time at 'turbo' speed in laboratory conditions (air-tight chamber with inner volume 1.4 m<sup>3</sup>, no air renewal). Human Coronavirus HCoV-229E is different from the virus responsible for COVID-19, SARS-CoV-2, but belongs to the same family of coronaviruses. | Daikin device MCK55WWM (commercial name MCK55W), tested by Institut Pasteur de Lille, removes 99.986 % of Influenza A virus subtype H1N1 in 2.5 minutes running time at 'turbo' speed in laboratory conditions (air-tight chamber with inner volume 0.47 m<sup>3</sup>, no air renewal). | Daikin device MC55WWM (commercial names MC55W/VB), tested by Institut Pasteur de Lille, removes 99.93 % of Influenza A virus subtype H1N1 in 2.5 minutes running time at 'turbo' speed in laboratory conditions (air-tight chamber with inner volume 0.47 m<sup>3</sup>, no air renewal). | Daikin device MCK70YVM (commercial names MCK70YV/YB), tested by Institut Pasteur de Lille, removes 99.98 % of Human Coronavirus HCoV-229E in 1.5 minutes running time at 'turbo' speed in laboratory conditions (air-tight chamber with inner volume 1.3 m<sup>3</sup>, no air renewal). Human Coronavirus HCoV-229E is different from the virus responsible for COVID-19, SARS-CoV-2, but belongs to the same family of coronaviruses. | Daikin device MCK70YVM (commercial names MCK70YV/YB), tested by Institut Pasteur de Lille, removes 99.65 % of Influenza A virus subtype H1N1 in 1.5 minutes running time at 'turbo' speed in laboratory conditions (air-tight chamber with inner volume 1.3 m<sup>3</sup>, no air renewal).

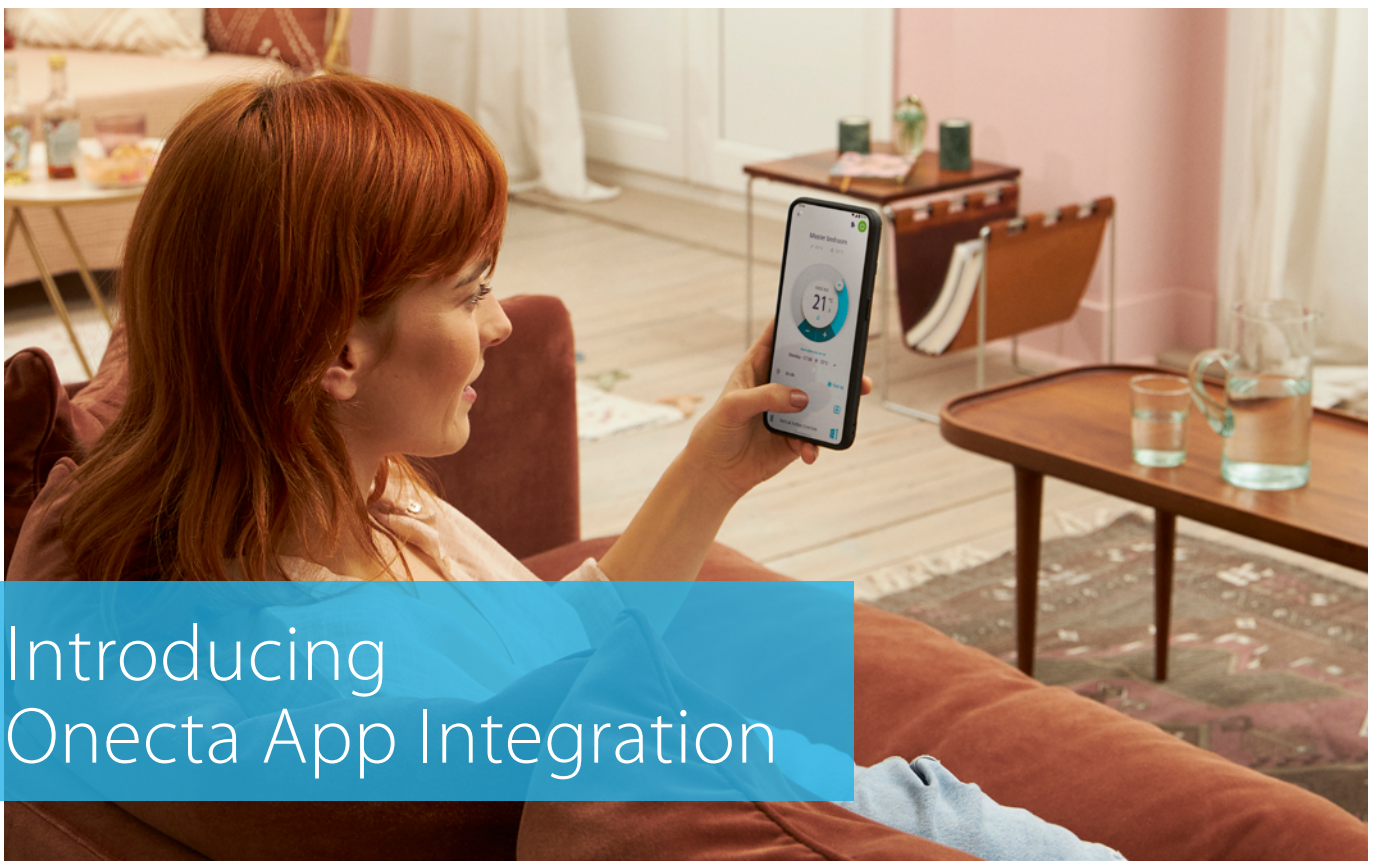

# Introducing Onecta App Integration

## Take control of your indoor air quality

The Onecta App is for those who live their life on the go and who want to manage their Daikin system from their smartphone.

The new models, MC80Z and MCK70Z come with Onecta App integration. For more information please refer to the product pages.

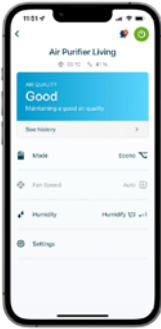

### Control

Customise the system to fit your lifestyle and year-round comfort levels.

- Adapt settings such as operation mode, fan speed, functions,...
- Take control of your indoor air quality by taking control of your Air purifier



### Monitor

Receive a thorough overview of how the system is performing and how much energy it consumes.

- Check the status of the Air Purifying system
- Access the PM2.5 graphs to evaluate your indoor air quality



### Schedule

Set up a programme outlining when the system should operate, and create up to six actions per day.

- Schedule operation mode depending on your personal needs
- Enable holiday mode to save costs



# Don't let bad outdoor air quality affect your indoor air quality

Indoor air can be **2-5 times worse** than outdoor air



At Daikin, we are constantly developing partnerships to bring in tools that keep you informed of your outdoor air quality to 'make the invisible visible' such that you don't let dirt accumulate inside your home and keep the air clean with our Daikin solution.

## Our Partnership with BreezoMeter

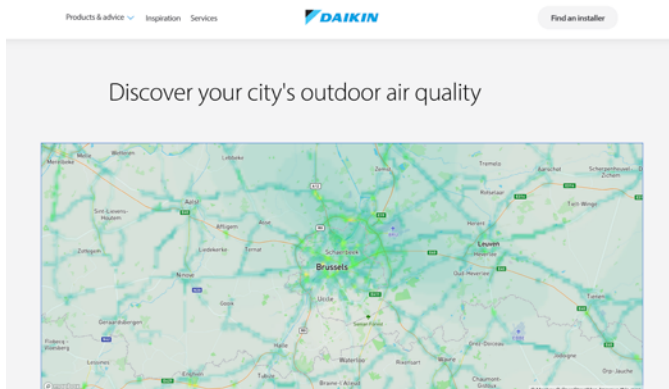

As ambassadors of Indoor Air Quality, Daikin has joined hands with BreezoMeter, now part of Google, which provides us with two API integrations on Air Quality & Pollen.

Our Daikin B2C website currently has PM2.5 map.

Our Onecta App currently gives all information related to Outdoor Air quality. Consumers can monitor information directly on their app.

Please stay tuned on our online websites for all on going updates.

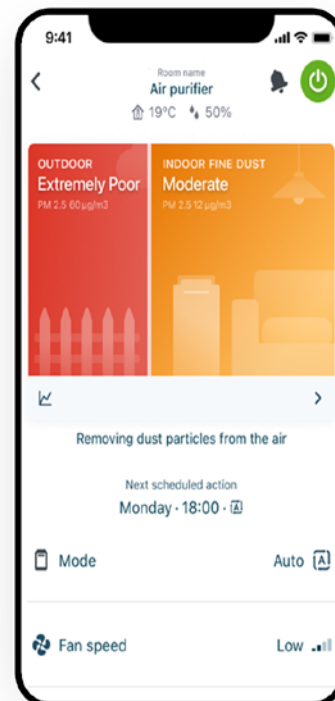

Discover more

Visit our new website to checkout the Outdoor Air Quality Map



# What makes our technology unique?

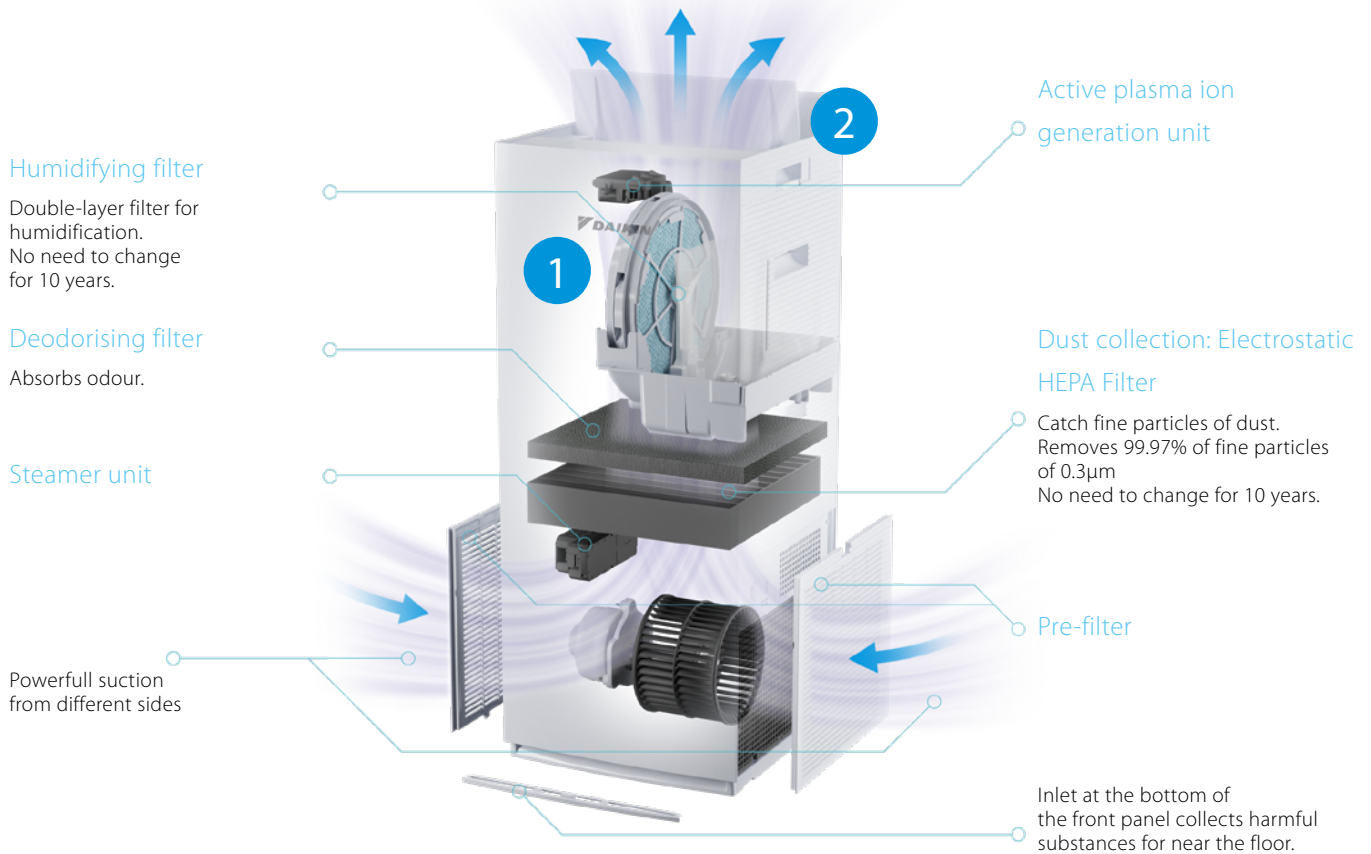

## Technology

### 1 INSIDE - Streamer decomposes hazardous elements

Streamer, a type of plasma discharge, decomposes hazardous chemical substances. The decomposition power is comparable to thermal energy of about 100,000°C.

### 2 OUTSIDE - Active plasma ion discharge\*

Plasma ion technology releases ions into the air by plasma discharge and combines them with components in the air to generate active components such as OH radicals with strong oxidising power. They attach to the surface of fungi and allergens and decompose proteins in the air by oxidation.

## The Streamer Symbol consists of three C's

### CATCH

The dust collection filter catches the floating substances with the attached harmful gases and Streamer decomposes the gases by oxidation.

### CYCLE

The deodorising filter absorbs and decomposes odour. Thanks to the regeneration of the adsorbing capacity, the deodorising capacity is maintained. No need to change the deodorising filter.

### CLEAN

Removes bacteria from dust collection filter, humidifying filter and humidifying water tray.

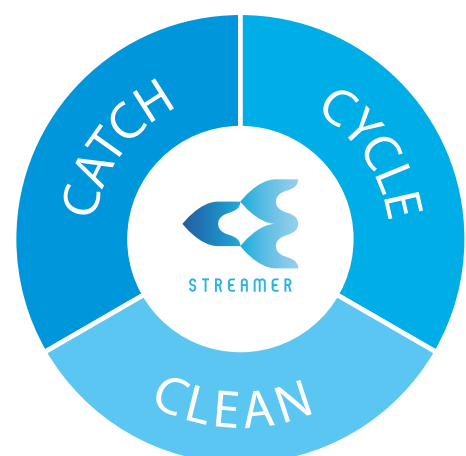

### Mechanism of decomposition by Streamer



Streamer emits high-speed electrons.



The electrons collide and combine with nitrogen and oxygen in the air to form four kinds of elements.

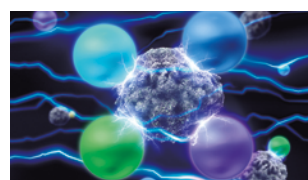

These elements provide decomposition power.





No hassle with periodic filter replacements



No maintenance costs for at least **10 years**



One of the **most silent** Air Purifier range on the European market

# Filter Lifetime

Our air purifiers feature a complete filtration system, with four stages of filtration to ensure your air is as clean as possible.

With our air purifiers, you can enjoy the benefits of clean, fresh air with minimal maintenance.



## 1. Pre filter

Our air purifiers feature an advanced pre-filter that helps to reduce the amount of pollutants that reach the main filter, which helps to extend the life of the air purifier and improve performance.

## 2. Filter HEPA Daikin

**High Performance Electrostatic HEPA Filter** is a high-efficiency particulate air filter system that is designed to catch fine particles of dust. Research shows they remove 99% of particles between 0.1µm and 2.5µm in size.

## 3. Deodorizing filter

Our air purifiers feature a powerful deodorizing filter that helps to reduce odours from cooking, smoking, pets, and other sources in the air.

## 3. Humidifying filter

Our air purifiers feature a built-in humidifying filter that helps to add moisture to the air.

This filter helps to keep the air from becoming too dry, which can cause problems such as static electricity and respiratory issues.

Please refer to product pages to check which units offer humidification.

## What makes Electrostatic HEPA better than Non-Electrostatic HEPA filter

- Removes 99.97% of fine particles of 0.3µm.
- Filter fiber itself is charged with static electricity, and collects particles efficiently.
- Doesn't clog easily, hence causes low pressure loss.

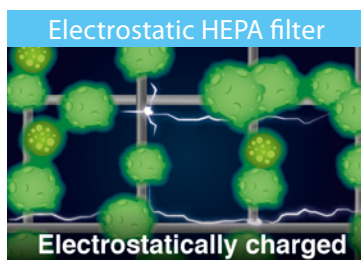

VERSUS

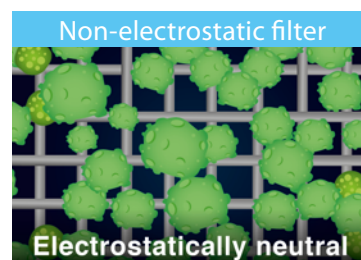

Because it catches particles relying only on mesh size, it is necessary to make mesh finer, making it easy to be clogged and cause high pressure loss.

### \*Mechanism of reduction by active plasma ions. (Concentration 25,000 ions/cm<sup>3</sup>.)

- Daikin's plasma ions have been proved safe, in relation to the effect on skin, eyes and respiratory organs.
- Testing organization: Life Science Laboratories, Ltd.
- Name of test: repeated-dose toxicity test.
- Test number: 12-II A2-0401 Mechanism of reduction by active plasma ions.

### About the dust collection and deodorizing capacity of an air purifier:

- Not all harmful substances in cigarette smoke (carbon monoxide, etc.) can be removed.
  - Not all odour components that emanate continuously (from building materials and pets, etc.) can be removed.
- The Daikin air purifier is not a medical device and is not meant to be used as a substitute to any medical or pharmaceutical treatment.

### HEPA filtration effect claims:

- Removes 99% of particles between 0.1µm and 2.5µm in size: test method: Japan Electrical Manufacturers' Association Standard JEM1467. Criterion: Remove 99% of fine particulate matters of 0.1 to 2.5µm in a closed space of 32m<sup>3</sup> within 90 minutes. (Converted to a value in a test space of 32m<sup>3</sup>).

### Deodorization/gas removal effect claims:

- Reduction of gases by oxidation: testing organization: Life Science Research Laboratory. Test method: After operating a gasoline engine for 10 minutes (when particulate concentration reached 60mg/m<sup>3</sup>), operated the air purifier for 80 minutes to absorb polluting particles emitted from the engine. Operated this air purifier for 24 hours in a closed space of 200L and measured the effect to decompose gases. Test result: Compared with a test without Streamer irradiation, gas components were reduced by 63% in 9 hours. Test number: LSLR-83023-702. Test unit: Tested with MCK70N (Japanese model).
- Adsorption and decomposition of odours: placed the air purifier and an odour component, acetaldehyde, in a box of 21 m<sup>3</sup> and operated the air purifier. Examined increase of concentration of product (CO) generated by decomposition of acetaldehyde by Streamer (evaluation by Daikin). Test unit: Tested with MCK55S (Japanese model), a model equivalent to MCK55W series.
- Formaldehyde decomposition: test method: constant generation method. Test room: 22 to 24 m<sup>3</sup>, temperature: 23 ± 3°C, humidity: 50 ± 20%. Ventilation condition: When concentration of 0.2 ppm is continually emanated, a removal capacity of 0.08 ppm is maintained at 36 m<sup>3</sup>/h, which is within the guideline of the Ministry of Health, Labour and Welfare in Japan. (This equates to the ventilation capacity of an approximately 65 m<sup>3</sup> room.)

### Substance decomposition effect claims:

- Removal of bacteria from dust collection filter: testing organization: Japan Food Research Laboratories. Test number: 15044988001-0201. Test method: Attached a test piece inoculated with bacteria liquid on the upstream side of a dust collection filter installed in an air purifier, and operated it in a test area of 25 m<sup>3</sup>. Counted the number of live bacteria after five hours. Test result: Reduced by more than 99% in five hours. Test unit: Tested with MCK55S (Japanese model), a model equivalent to MCK55W series (turbo operation).
- Removal of bacteria from humidifying filter: testing organization: Japan Food Research Laboratories. Test number: 15044989001-0101. Test method: Attached a test piece inoculated with bacteria liquid on the upstream side of a humidifying filter installed in an air purifier, and operated it in a test area of 25 m<sup>3</sup>. Counted the number of live bacteria after five hours. Object part: Humidifying filter. Test result: Reduced by more than 99% in five hours. Test unit: Tested with MCK55S (Japanese model), a model equivalent to MCK55W series (turbo operation).
- Allergen decomposition and removal: various allergens were irradiated by streamer discharge and the breakdown of protein in the allergens was verified using the ELISA method, cataphoresis, or an electron microscope (Joint research with Wakayama Medical University). Test example: Japanese cedar pollen Cryj-1. Test result: 99.6% or more decomposed and removed in 2 hours (ELISA method); 96.9% decomposed and removed in 4 hours (other measurement method). Note: test performed on the flash streamer module.
- Virus removal ref. 1: testing organization: Kitasato Research Center for Environmental Science. Test result certificate 2L\_0026 (issued by same organization). Result of experiment: 99.9% removal of A-H1N1 virus after 1 hour. Note: test performed on the flash streamer module.
- Virus removal ref. 2: testing organization: Vietnamese Institute of Hygiene and Epidemiology. Result of experiment: over 99.9% removal of A-H5N1 virus in 3 hours. Note: test performed on the flash streamer module.
- Virus removal ref. 3: testing organization: Graduate School of Kobe University. Result of experiment: over 96% removal of Norovirus in 24 hours. Note: test performed on the flash streamer module.



## Intelligent Air Purification, minimalistic design & Humidification MCK70Z

- › Onecta App Integration: control indoor with an app, via local network or internet
- › Humidification and air purification in one; covers large spaces up to 96m<sup>2</sup>
- › Intuitive display design with coloured Daikin Eye, visual way of informing users about indoor air quality
- › Pure air thanks to Daikin's 'catch and clean' approach in decomposing harmful substances
- › High performance HEPA filter with no need to change for 10 years
- › Whisper Quiet operation (down to 18dB(A))

### Sensors

Dust (PM2.5/dust) sensor	•
Odour sensor	•
Temperature sensor	•
Humidity sensor	•

### Mode

Auto fan mode	•
Anti-pollen mode	•
Turbo mode	•
Quiet mode	•
Econo mode	•
Circulation mode	•
Moist mode	•

### Functions

Catch & clean	•
Deodorizing filter	•
Onecta app	•
Child proof lock	•
Brightness adjustment	•
Auto restart after power failure	•

NEW



- Air flow up to **420 m<sup>3</sup>/h**
- Air purification up to **96 m<sup>2</sup>**
- Intelligent** air purification
- Absorbs odour via **deodorising filter**
- High Performing Electrostatic **HEPA filter**



## Specifications



Indoor Unit				70ZW/70ZBFW	70ZH/70ZBFH
Applicable room area			m <sup>2</sup>	48(1)/96(2)	
CADR			m <sup>2</sup>	375	
Weight	Unit		kg	12.5	
Dimensions	Unit	HeightxWidthxDepth	mm	760x315x315	
Colour				White	Gray
Air flow rate		Air purifying operation	Silent/Low/Medium/Turbo	m <sup>3</sup> /h	84/132/210/420
		Humidifying operation	Silent/Low/Medium/Turbo	m <sup>3</sup> /h	84/132/210/420
Sound pressure level	Air purifying operation	Silent/Low/Medium/Turbo		dBA	18/27/37/54
	Humidifying operation	Silent/Low/Medium/Turbo		dBA	18/27/37/54
Humidifying operation	Power input	Silent/L/M/Turbo		kW	0.010/0.012/0.023/0.084
	Humidification	Turbo		ml/h	700
	Water tank capacity			l	3.4
Air purifying operation	Power input	Silent/L/M/Turbo		kW	0.010/0.011/0.020/0.082
Power supply	Phase/Frequency/Voltage			Hz/V	1~/50/60/220-240/220-230

(1)The coverage area is appropriate for operating the unit of maximum fan speed(HH). Coverage area indicates the space where a certain amount of dust particles can be removed in 30 minutes. | (2)Converted to NRCC standards from test values in accordance with JEM1467. | Converted to CADR standards from test values in accordance with JEM1467. | Humidification amount changes in accordance with indoor and outdoor temperature and humidity. Measurement condition: 20°C in temperature, 30% in humidity. | Operating sound levels are the average of values measured at 1m away from the front, left, right and top of the unit. (These are equal to the values in an anechoic chamber) | Electrostatic HEPA filter and humidifying filters are attached in the unit. | Requirements according to JEM1467. | "HI" is displayed when the PM2.5 concentration exceeds 99µg/m<sup>3</sup>.





Intelligent Air Purification,  
minimalistic design  
**MC80Z**

- › Onecta App Integration: control indoor with an app, via local network or internet
- › Air purification of large spaces up to 124m<sup>2</sup>
- › Intuitive display design with coloured Daikin Eye, visual way of informing users about indoor air quality
- › Pure air thanks to Daikin's 'catch and clean' approach in decomposing harmful substances
- › High performance HEPA filter with no need to change for 10 years
- › Whisper Quiet operation (down to 19dB(A))



**NEW**

- Air flow up to **480 m<sup>3</sup>/h**
- Air purification up to **124 m<sup>2</sup>**
- Intelligent** air purification
- Absorbs odour via **deodorising filter**
- High Performing Electrostatic **HEPA filter**



### Sensors

Dust (PM2.5/dust) sensor	•
Odour sensor	•
Temperature sensor	•

### Mode

Auto fan mode	•
Anti-pollen mode	•
Turbo mode	•
Quiet mode	•
Econo mode	•
Circulation mode	•

### Functions

Catch & clean	•
Deodorizing filter	•
Onecta app	•
Child proof lock	•
Brightness adjustment	•
Auto restart after power failure	•

## Specifications



Indoor Unit				80ZB	80Z
Applicable room area				m <sup>2</sup>	62(1)/124(2)
CADR				m <sup>2</sup>	480
Weight	Unit			kg	9.8
Dimensions	Unit	HeightxWidthxDepth		mm	630x315x315
Colour					Front: White, Top/Side: Dark Grey
Air flow rate		Air purifying operation	Silent/Low/Medium/Turbo	m <sup>3</sup> /h	84/132/210/480
Sound pressure level	Air purifying operation	Silent/Low/Medium/Turbo		dB(A)	19/25/34/55
Air purifying operation	Power input	Silent/L/M/Turbo		kW	0.010/0.011/0.020/0.082
Power supply	Phase/Frequency/Voltage			Hz/V	1~/50/60/220-240/220-230

(1)The coverage area is appropriate for operating the unit of maximum fan speed(HH). Coverage area indicates the space where a certain amount of dust particles can be removed in 30 minutes. | (2)Converted to NRCC standards from test values in accordance with JEM1467. | Converted to CADR standards from test values in accordance with JEM1467. | Operating sound levels are the average of values measured at 1m away from the front, left, right and top of the unit. (These are equal to the values in anechoic chamber) | Electrostatic HEPA filter is attached in the unit. | Other function: Active plasma ion function. Autorestartfunction. | Requirements according to JEM1467. | \*HI\* is displayed when the PM2.5 concentration exceeds 99µg/m3.





## Powerful Air Purification MC30Y

- › Air treatment up to 46m<sup>2</sup>
- › Pure air thanks to 'Catch and Clean' approach
- › No need to change filter for 10 years thanks to high performance electrostatic HEPA filter
- › Whisper quiet operation (19 dB(A))

- Air flow up to **180 m<sup>3</sup>/h**
- Air purification up to **46 m<sup>2</sup>**
- Absorbs odour via **deodorising filter**
- High Performing Electrostatic **HEPA filter**



### Mode

Turbo mode	•
Quiet mode/sleep mode	•

### Functions

Catch & clean	•
Deodorizing filter	•
Child proof lock	•
Brightness adjustment	•
Auto restart after power failure	•



## Specifications



MC30YV



MC30YB

Technical specifications		MC	MC30YV/YB
Applicable room area			23(1)/46(2)
CADR		m <sup>3</sup> /h	180
Weight	Unit	kg	5.8
Dimensions		mm	565/350/345
Colour			White
Air flow rate	Air purifying operation	Silent/Medium/Turbo	m <sup>3</sup> /h
			60/120/180
Sound pressure level	Air purifying operation	Silent/Medium/Turbo	dBA
			19/27/37
Air purifying operation	Power input	Silent/Medium/Turbo	kW
			0.008/0.015/0.025
Power supply	Phase/Frequency/Voltage		1~/50/60/220-240/220-30

Standard accessories: Electrostatic HEPA filter; Quantity: 1;

Standard accessories: Deodorising filter; Quantity: 1;

Standard accessories: Operation manual; Quantity: 1;

(1) The applicable room area is appropriate for operating the unit of maximum fan speed (HH). Applicable room area indicates the space where a certain amount of dust particles can be removed in 30 minutes. (JEM 1467) | (2) The applicable room area is appropriate for operating the unit of maximum fan speed (HH). Applicable room area was calculated in accordance with NRCC-54013 standard using cigarette smoke CADR that was tested according to JEM1467. | Converted to CADR standards from test values in accordance with JEM1467. | Operating sound levels are the average of values measured at 1m away from the front, left, right and top of the unit. (These are equal to the values in an anechoic chamber) | Electrostatic HEPA filter is attached in the unit. | Other function: Auto-restart function.



## Compact, effective, and quiet MC55W

- › Effectiveness against respiratory viruses evaluated by Institut Pasteur de Lille
- › Pure air thanks to Daikin 'Catch and Clean' approach in decomposing harmful substances
- › High performance HEPA filter with no need to change for 10 years
- › Whisper quiet
- › Colour LEDs to provide info about indoor air quality

### Sensors

Dust (PM2.5/dust) sensor	•
Odour sensor	•

### Mode

Auto fan mode	•
Anti-pollen mode	•
Turbo mode	•
Quiet mode	•
Econo mode	•

### Functions

Catch & clean	•
Deodorizing filter	•
Remote Controller	•
Child proof lock	•
Brightness adjustment	•
Auto restart after power failure	•

## Specifications

Single Unit				MC55W / MC55VB	
Applicable room area			m <sup>2</sup>	41(1)/82(2)	
Dimensions	Unit	HeightxWidthxDepth	mm	500x270x270	
Weight	Unit		kg	6.8	
Colour				White	
Air flow rate		Air purifying operation	Silent/Low/Medium/Turbo	m <sup>3</sup> /h	66/120/192/330
Sound pressure level	Air purifying operation		Silent/Low/Medium/Turbo	dBA	19/29/39/53
Air purifying operation	Power input		Silent/Low/Medium/Turbo	kW	0.008/0.010/0.015/0.037
Power supply	Phase/Frequency/Voltage			Hz/V	1~/50/60/220-240/220-230
Power plug					W: C type/VB: G type (UK)

The applicable room area is appropriate for operating the unit of maximum fan speed (HH). Applicable room area indicates the space where a certain amount of dust particles can be removed in 30 minutes. ((1) in accordance with JEM (2) in accordance with CADR (JEM) & NRCC-54013-2011 standard) | Operating sound levels are the average of values measured at 1m away from the front, left, right and top of the unit. (These are equal to the values in an anechoic chamber) | Electrostatic HEPA filter is attached in the unit. | Other function: Active plasmatron function. Auto-restart function. About the dust collection and deodorizing capacity of an air purifier:

- › Not all harmful substances in cigarette smoke (carbon monoxide, etc.) can be removed.
  - › Not all odour components that emanate continuously (from building materials and pets, etc.) can be removed.
- The Daikin air purifier is not a medical device and is not meant to be used as a substitute to any medical or pharmaceutical treatment.

- Air flow up to **330 m<sup>3</sup>/h**
- Air purification up to **82 m<sup>2</sup>**
- Absorbs odour via **deodorising filter**
- High Performing Electrostatic **HEPA filter**



MC55W



MC55VB



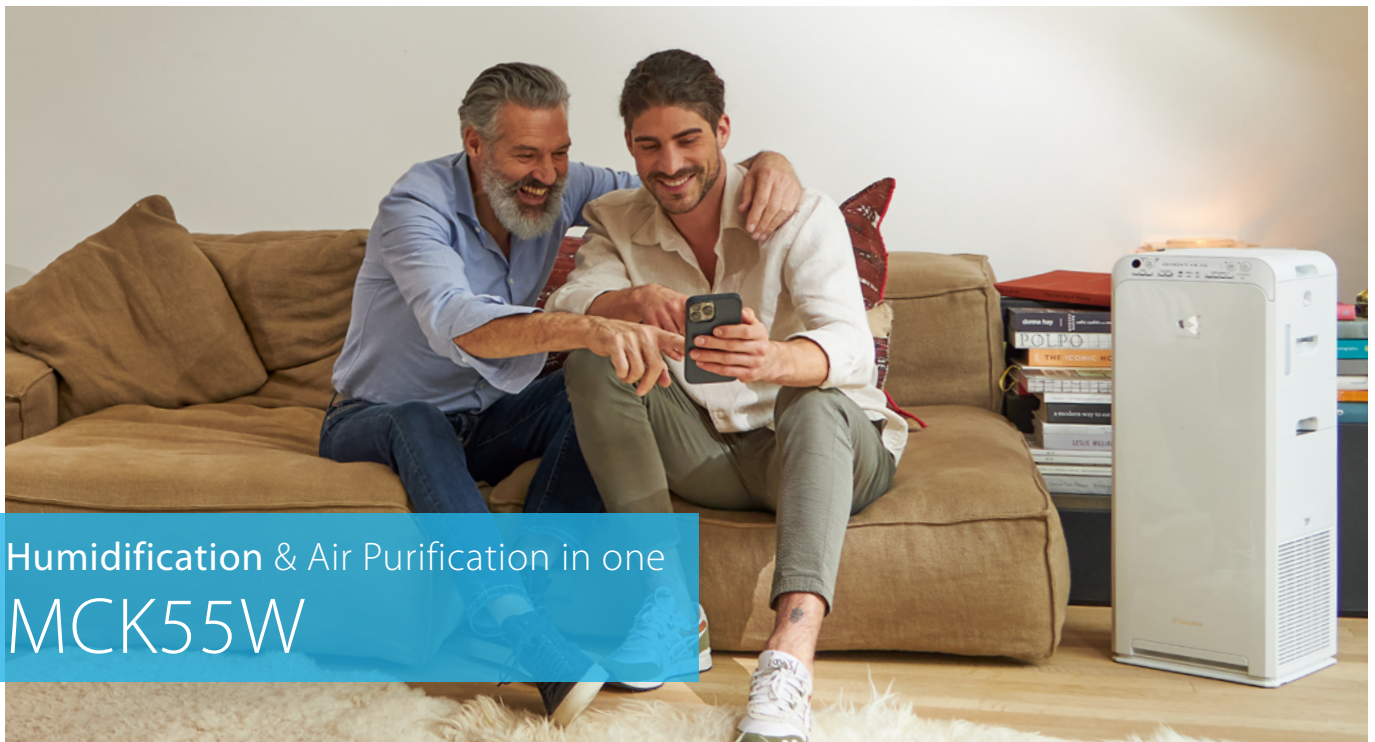

## Humidification & Air Purification in one MCK55W

- › Effectiveness against respiratory viruses evaluated by Institut Pasteur de Lille
- › Humidification and purification in one
- › Pure air thanks to Daikin 'Catch and Clean' approach in decomposing harmful substances
- › High performance HEPA filter with no need to change for 10 years
- › Whisper quiet
- › Colour LEDs to provide info about indoor air quality



- Air flow up to **330 m<sup>3</sup>/h**
- Air purification up to **82 m<sup>2</sup>**
- 500 ml/h** humidifying capacity
- Absorbs odour via **deodorizing filter**
- High Performing Electrostatic **HEPA filter**

### Sensors

Dust (PM2.5/dust) sensor	•
Odour sensor	•
Humidity sensor	•

### Mode

Auto fan mode	•
Anti-pollen mode	•
Turbo mode	•
Quiet mode	•
Econo mode	•
Moist mode	•

### Functions

Catch & clean	•
Deodorizing filter	•
Remote Controller	•
Child proof lock	•
Brightness adjustment	•
Auto restart after power failure	•



## Specifications



Single Unit				MCK55W	
Applicable room area			m <sup>2</sup>	41(1)/82(2)	
Dimensions	Unit	HeightxWidthxDepth	mm	700x270x270	
Weight	Unit		kg	9.5	
Colour				White	
Air flow rate		Air purifying operation	Silent/Low/Medium/Turbo	m <sup>3</sup> /h	54/120/192/330
		Humidifying operation	Silent/Low/Medium/Turbo	m <sup>3</sup> /h	102/144/192/330
Sound pressure level	Air purifying operation	Silent/Low/Medium/Turbo		dB(A)	19.0/29.0/39.0/53.0
	Humidifying operation	Silent/Low/Medium/Turbo		dB(A)	25.0/33.0/39.0/53.0
Humidifying operation	Power input	Silent/L/M/Turbo		kW	0.011/0.014/0.019/0.058
	Humidification	Silent/Low/Medium/Turbo		ml/h	200/240/300/500
	Water tank capacity			l	2.7
Air purifying operation	Power input	Silent/L/M/Turbo		kW	0.007/0.010/0.017/0.056
Power supply	Phase/Frequency/Voltage			Hz/V	1~/50/60/220-240/220-230

The applicable room area is appropriate for operating the unit of maximum fan speed (HH). Applicable room area indicates the space where a certain amount of dust particles can be removed in 30 minutes. (1) in accordance with JEM (2) in accordance with CADR (JEM) & NRCC-54013-2011 standard | Humidification amount changes in accordance with indoor and outdoor temperature and humidity. Measurement condition: 20°C in temperature, 30% in humidity. | Operating sound levels are the average of values measured at 1m away from the front, left, right and top of the unit. (These are equal to the values in an anechoic chamber) | Electrostatic HEPA filter and humidifying filters are attached in the unit.





## High grade type humidification MCK70Y

- › Air purification for large spaces such as residential and light commercial applications
- › Pure air thanks to Daikin 'Catch and Clean' approach in decomposing harmful substances
- › High performance HEPA filter with no need to change for 10 years
- › Whisper quiet
- › Colour LEDs to provide info about indoor air quality

- Air flow up to **420 m<sup>3</sup>/h**
- Air purification up to **96 m<sup>2</sup>**
- 650 ml/h** humidifying capacity
- Absorbs odour via **deodorising filter**
- High Performing Electrostatic **HEPA filter**



### Sensors

Dust (PM2.5/dust) sensor	•
Odour sensor	•
Humidity sensor	•

### Mode

Auto fan mode	•
Anti-pollen mode	•
Turbo mode	•
Quiet mode	•
Econo mode	•
Circulation mode	•
Moist mode	•

### Functions

Catch & clean	•
Deodorizing filter	•
Child proof lock	•
Brightness adjustment	•
Auto restart after power failure	•

## Specifications

Indoor Unit				MCK70YV	MCK70YB
Applicable room area				m <sup>2</sup>	48(1)/96(2)
Dimensions	Unit	HeightxWidthxDepth		mm	600x395x287 (3)
Weight	Unit			kg	12.5
Colour					White
Air flow rate		Air purifying operation	Silent/Low/Medium/Turbo	m <sup>3</sup> /h	60/132/210/420
		Humidifying operation	Silent/Low/Medium/Turbo	m <sup>3</sup> /h	102/132/210/420
Sound pressure level	Air purifying operation	Silent/Low/Medium/Turbo		dBA	18/27/37/54
	Humidifying operation	Silent/Low/Medium/Turbo		dBA	23/27/37/54
Humidifying operation	Power input	Silent/L/M/Turbo		kW	0.011/0.012/0.018/0.068
	Humidification	Turbo		ml/h	650
		Water tank capacity		l	3.6
Air purifying operation	Power input	Silent/L/M/Turbo		kW	0.008/0.010/0.016/0.066
Power supply	Phase/Frequency/Voltage			Hz/V	1~/50/60/220-240/220-230

The applicable room area is appropriate for operating the unit of maximum fan speed (HH). Applicable room area indicates the space where a certain amount of dust particles can be removed in 30 minutes. ((1) in accordance with JEM (2) in accordance with CADR (JEM) & NRCC-54013-2011 standard) (3) With caster: 637 × 395 × 287 | Humidification amount changes in accordance with indoor and outdoor temperature and humidity. Measurement condition: 20°C in temperature, 30% in humidity. | Operating sound levels are the average of values measured at 1m away from the front, left, right and top of the unit. (These are equal to the values in an anechoic chamber) | Electrostatic HEPA filter and humidifying filters are attached in the unit.



MCK70YV



MCK70YB





# Residential ventilation

Centralized Heat Recovery  
Ventilation (CHRV)





# Why DUCO?

## DUCO offers end-to-end solutions

### One-stop-shop for your end-to-end ventilation solution

Complete range of Centralized Heat Recovery Ventilation (CHRV) units, ducts & accessories.

### Smart demand control

The room is only ventilated when necessary and in the correct amount. CO<sub>2</sub> concentration and air humidity are used as indicators. This helps avoiding unnecessary heat loss while guaranteeing an optimal indoor climate.

### Low noise guaranteed

A comfortable indoor climate is created by whisper-quiet ventilation systems. DUCO excels in acoustics both in its supply and exhaust airs.

### Intuitive quotation process

Upon request, Daikin can provide an easy-to-use tool to calculate the units and accessories needed for your specific projects. A complete calculation request can also be carried out on Daikin Heating Solutions Navigator Platform.

### Automatic calibration

The automatic calibration, whereby the measuring and adjustment technology is based on the principles of calibration under constant pressure, always offers a 100% guarantee of a qualitative end result and translates into a 50% saving in set-up time for the installer.

### Connectivity

With the optional Communication Print you have the option of allowing the DUCO ventilation systems to communicate via ModBus and/or Ethernet. ModBus integration enables them to be linked to a building management system.

### High energy conversion efficiency

The combination of dynamic air distribution filters and high performance heat exchangers result in very high efficiency ratio.

## Only at Daikin

Thanks to DUCO, Daikin offers Centralized HRV systems with an integrated 2-zone valve. With the 2-zone version of the DucoBox Energy Premium, Daikin's product range is extended with a unique ventilation system with embedded 2-zone control. If a certain zone does not require ventilation, that zone is not ventilated. Cost savings on heating, lower consumption and noise comfort of the unit itself (lower rpm) are the logical consequences.

Sensors meticulously detect the residents' movements throughout the home. This makes it possible to automatically determine where, when and in what amount ventilation is required.

By controlling the two zones separately with a built-in valve, the consumption of the EC fans is reduced considerably, which translates into an A+ energy label.

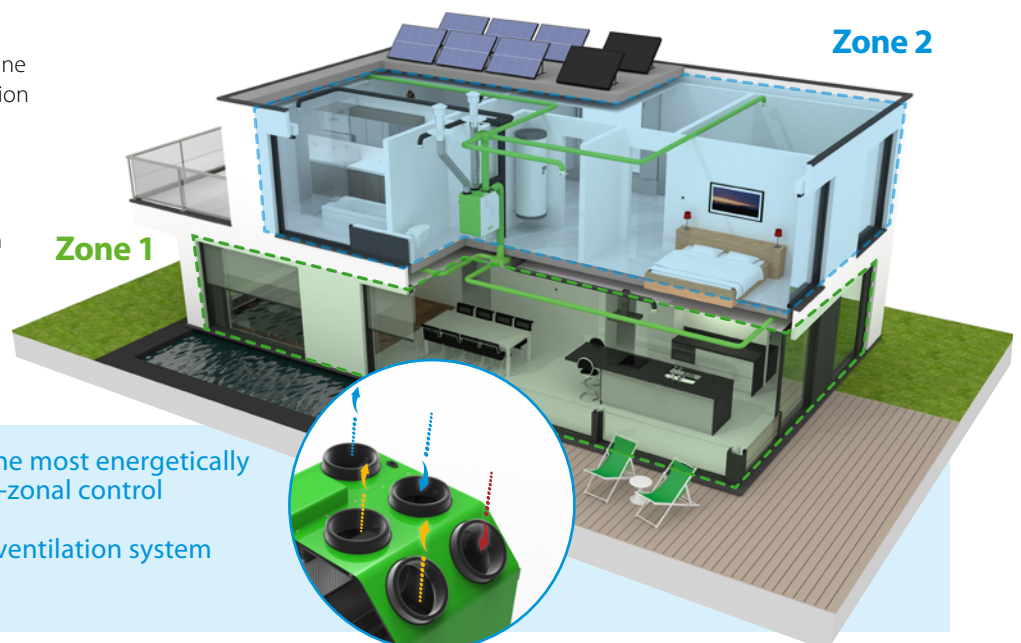

- ✓ Optimal indoor air quality in the most energetically optimised manner thanks to 2-zonal control
- ✓ Low noise guaranteed by our ventilation system
- ✓ Automatic calibration



# A complete portfolio for complete ventilation solutions

Clean air, whenever you need!

Europe's QUIETEST and SMARTEST CHR.V!



## DucoBox Energy Comfort & Comfort Plus

✓  
**A solution for every situation**  
Flow rate up to 550m<sup>3</sup>/h (at 200 Pa)

✓  
**Left/right exchangeable**  
Exchange between left and right variant is carried out 100% by software

✓  
**Automatic calibration**  
Calibration at constant pressure saves up to 50% on the configuration time



## DucoBox Energy Premium

✓  
**Smart 2-zone control**  
Saving up to 40% through smart zone control

✓  
**Quietest CHR.V on the market**  
Enjoy a good night's sleep!

✓  
**Automatic calibration**  
Calibration at constant pressure saves up to 50% on the configuration time

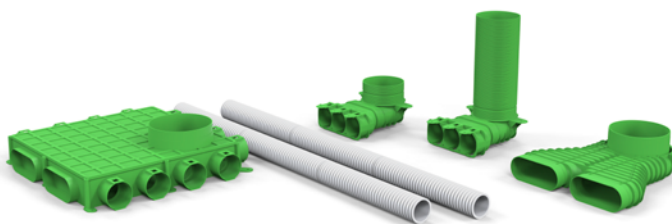

## DucoFlex

Thanks to DUCO, with DucoFlex, Daikin offers a complete air ducting system. If you use this installation-friendly air-duct system you will enjoy the energy-efficient and quiet operation of the ventilation system.

For more information on Ducoflex, please refer to the dedicated page on ducting solutions



# On-demand ventilation for all needs

Only ventilate, when necessary, where it is necessary and as long as it is necessary!

Thanks to DUCO, Daikin brings to you the SMARTEST ventilation solution. On-demand ventilation allows remote control and intelligent usage of the ventilation system, increasing comfort and convenience for the end user.

### How does it work?

Local and/or central sensors permanently measure the indoor air quality in your home. If the air quality is decreasing, the ventilation is triggered immediately according to intelligent algorithms to create a health environment again.

### Compact external 2-zone control

With external 2-zone control, the house is divided into a **day and night zone**.

This zonal control is **based on CO<sub>2</sub> and humidity**. It only provides ventilation **where and when needed**, in the right amount.

**Zonal ventilation** ensures **maximum energy savings** and increases **acoustic and thermal comfort**.



Discover the **4 benefits** of the multi-zone valve:

<p>Compact installation</p>	<p>Energy savings</p>	<p>Quieter operation</p>	<p>Enhanced thermal comfort</p>
-----------------------------	-----------------------	--------------------------	---------------------------------

# DucoBox Energy Comfort



## Making life easy for installers

- ✓ Patented principle of double by-pass

- ✓ Dynamic Airflow Filters

For maximum efficiency.

- ✓ Low power consumption due to energy-efficient EC motors

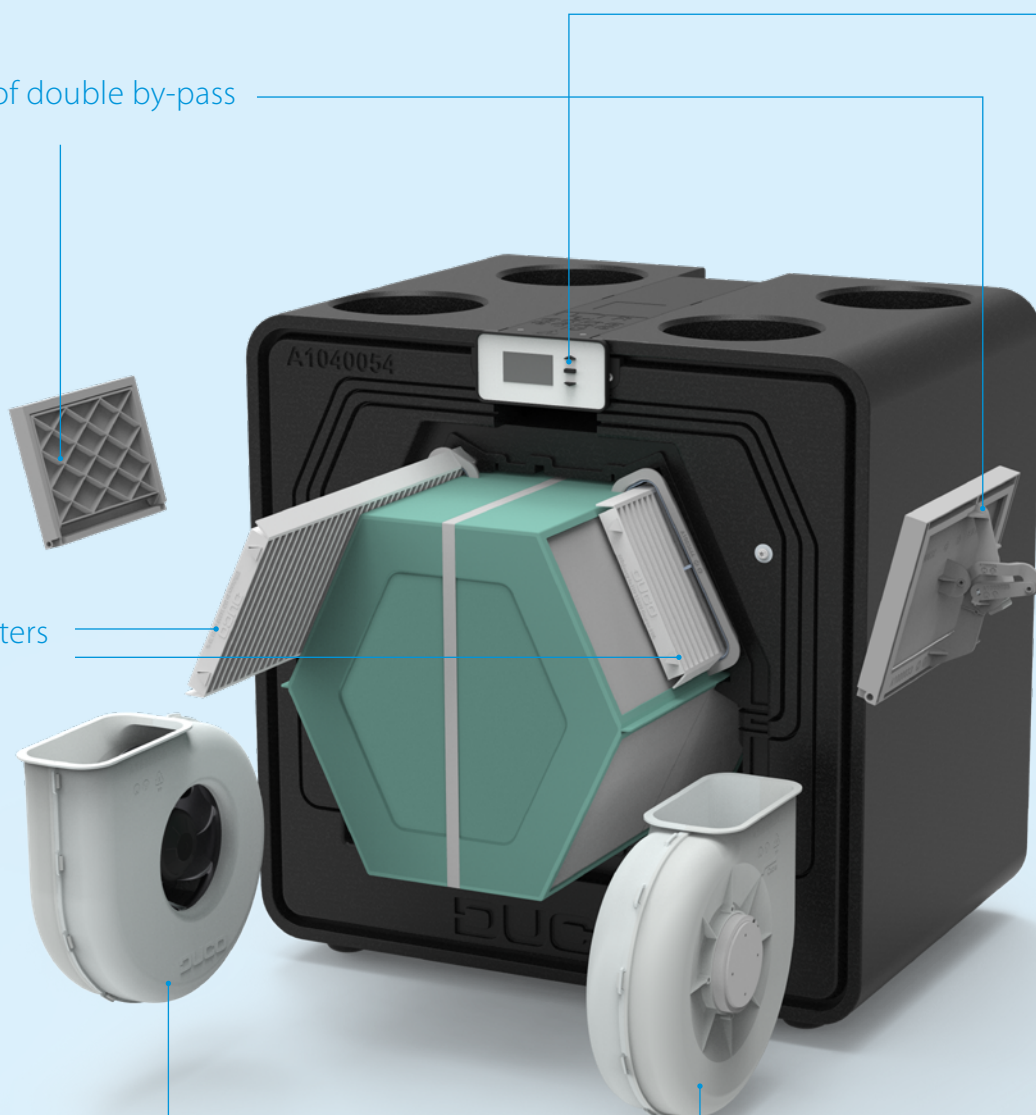



# First choice for building projects

This smart and silent ventilation unit is the ideal solution for apartments and houses due to its compact size. With the addition of DucoBox Energy Comfort D400 to our portfolio, this range now offers adjustable capacity of up to 325 m<sup>3</sup>/h and 400 m<sup>3</sup>/h. The left/right switch is 100% software-driven thanks to the patented principle of double bypass. The dynamic air distribution filters, together with the smart demand control based on CO<sub>2</sub> and humidity, ensure for exceptional efficiency within this compact unit.

- ✓ Optional pre-heater and optional multi-zoning valve

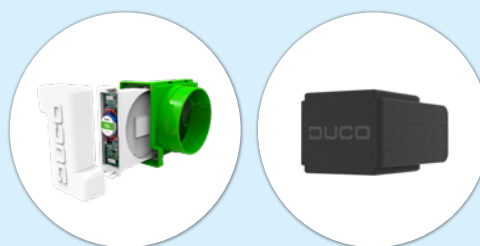

- ✓ L/R switch - 100% software-based

This unit is very user-friendly because physical interventions are not necessary. The left/right switch is carried out 100% by software thanks to a patented principle of double by-pass.



- ✓ Compact & light unit:



This lightweight unit starting from 21kg can easily be installed by 1 person. With its compact dimensions, the DucoBox Energy Comfort is ideal for a small technical space!

- ✓ Smart copy function

Thanks to a "copy" function which is integrated on software level, the installer has the possibility to copy the settings and parametrisation of one DucoBox Energy Comfort onto the next DucoBox Energy Comfort. This is particularly useful in a serial construction with the same types of houses.



- ✓ Automatic calibration

Relying on the principles of calibration at constant pressure, this method achieves a 50% saving on calibration time. DUCO saves you time.

- ✓ Smart demand control based on CO<sub>2</sub> and/or humidity measurement



# DucoBox Energy Comfort 325- D400

The DucoBox Energy Comfort is a compact and light mechanical ventilation unit with heat recovery. With a capacity of up to 400 m<sup>3</sup>/h, this is the balanced ventilation solution for apartments and serial housing construction.

The **demand control** of the DucoBox Energy Comfort results in intelligent and energy-efficient operation.

Together with the **smart demand control** based on CO<sub>2</sub> and humidity, the dynamic air distribution filters ensure exceptional efficiency within this compact unit.

The **left/right switch** is carried out 100% by software thanks to a patented principle of double bypass.

Moreover, this lightweight unit weighs just 21 kg. In other words: easy to install by 1 person.

The **automatic configuration** ensures the device can be installed quickly and professionally.

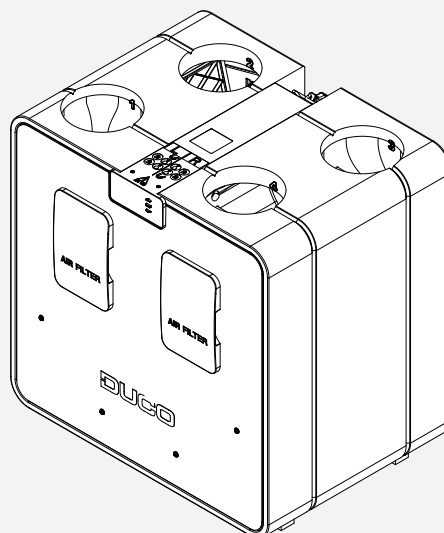
 A<sup>+</sup>

## Versions

Type	Supply and exhaust airflow rate at 150 Pa	2-zone control	Frost protection	Reference number
DucoBox Energy Comfort 325	325 m <sup>3</sup> /h	yes (as external option)	Imbalance or optional external heater	00004649

Type	Pulsion and extraction capacity at 150 Pa	Pulsion and extraction capacity at 200 Pa	2-zone system	Frost protection	Item Number
DucoBox Energy Comfort D400	400 m <sup>3</sup> /h	400 m <sup>3</sup> /h	yes (as external option)	Imbalance or optional external heater	00004707

## Optional Accessories DucoBox Energy Comfort 325

Product	Reference Number
Siphon flat (Energy & Eco)	00004376
Communication Print	00004251
Humidity Sensor (Energy Comfort & Energy Comfort Plus)	00004723
Mounting Chair Standing (Energy Comfort D325)	00004546
Filter set 2 x Coarse 65% (Energy Comfort D325)	00004547
Filter set Coarse 65% / ePM1 55% (Energy Comfort D325)	00004661
Coaxial cable set 8 m	00004418

## Optional Accessories DucoBox Energy Comfort D400

Product	Reference Number
Siphon flat (Energy & Eco)	00004376
Communication Print	00004251
Humidity Sensor (Energy Comfort & Energy Comfort Plus)	00004723
Standing support frame (Energy Comfort D400 / Plus)	00004740
Filter set 2 x Coarse 65% (Energy Comfort D400/Plus)	00004741
Filterset Coarse 65%/ePM1 55% (Energy Comfort D400 & Plus D350/D450/D550)	00004742
Coaxial cable set 8 m	00004418

# DucoBox Energy Comfort 325- D400

More details and final information  
can be found by scanning or  
clicking the QR codes.



DucoBox Energy Comfort

Physical Properties	325	D400
Width x Height x Depth (mm)	700 x 705 x 525 mm	756 x 800 x 584 mm
Casing	Coated sheet steel + EPP	
Colours	White + Black	
Connections	Inner Diameter: Ø 160mm	Inner Diameter: Ø 180mm
Condensate drain	Ø 32 mm (1 ¼") (2x)	
Heat exchanger	PET/ Polystyrene	v1: PP - v2: PET/Alu
Material of inside section	EPP / PP / ABS	
Weight	21 kg	31 kg
Power cable length	2 m (from top of unit)	
Mounting	Wall mounting (standard) Floor mounting as an option using support frame	
Miscellaneous Properties	325	D400
Energy class	With 2 sensors (control factor 0.65): A+ Other: A	
Filters	Dynamic airflow filter supply air (460 x 185 x 15 mm) Standard: ISO 16890 Coarse 65 % (= G4) Optional: ISO 16890 ePM1 55% (=F7) Dynamic airflow filter exhaust air (460 x 185 x 15 mm) Standard: ISO 16890 Coarse 65 % (= G4)	Dynamic airflow filter supply air (520 x 190 x 15 mm) Standard: ISO 16890 Coarse 65 % (= G4) Optional: ISO 16890 ePM1 55% (=F7) Dynamic airflow filter exhaust air (520 x 190 x 15 mm) Standard: ISO 16890 Coarse 65 % (= G4)
Summer by-pass	Fully (100% modulating)	
Frost protection	Imbalance or external heater	
Fans	EC fan with backward curved blades	
Automatic Calibration	Yes (constant pressure)	
Constant flow regulation	Yes	
Passive cooling	Automatic passive cooling control	
Operation	Integrated display Use via User controllers and CO <sub>2</sub> or Humidity Sensors Via smartphone / tablet as an option (provided device has Communication Print)	
Sensors	Integrated: pressure, temperature, onboard switch sensor External: CO <sub>2</sub> (via optional Sensor), Humidity (via optional Sensor or measurement in ETA line), external Switch Sensor (voltage-free input) (optional)	
Communication	Standard: Duco RF, Duco Wired, Switch Sensor Expandable with Communication Print: ModBus, PWM-IN, PWM-OUT, Switch Sensor (3x), Ethernet, Micro SD-card slot	
Electrical Characteristics	325	D400
Maximum electrical power	118 W (2 x 59 W)	145 W (2 x 72.5 W)
Power Supply	230 V, 50 Hz Via 3-core power cable with earthed plug	
Contacts	0-10 V in/output	
Type of motor	DC	
Energy conversion efficiency	At 325 m <sup>3</sup> /h: 85% At 279 m <sup>3</sup> /h: 86% At 277 m <sup>3</sup> /h: 88%	At 400 m <sup>3</sup> /h: 83% At 351 m <sup>3</sup> /h: 84% At 307 m <sup>3</sup> /h: 85%



## Dimensions DucoBox Energy Comfort D400

Front view

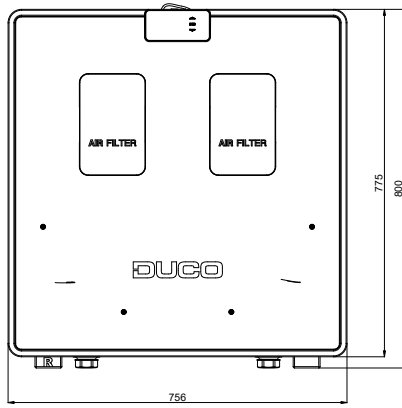

Rear view

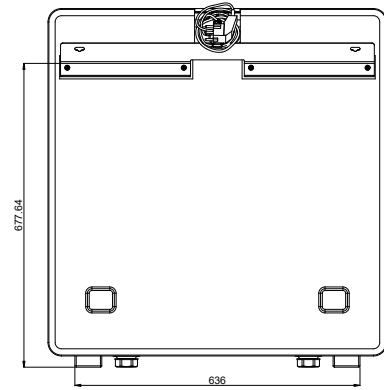

Top view

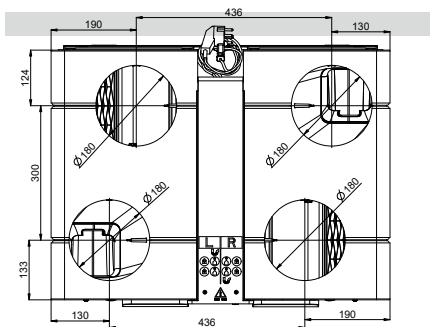

Bottom view

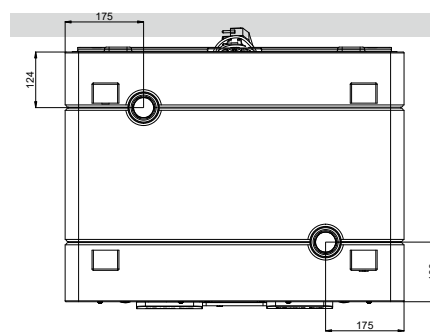

Side view

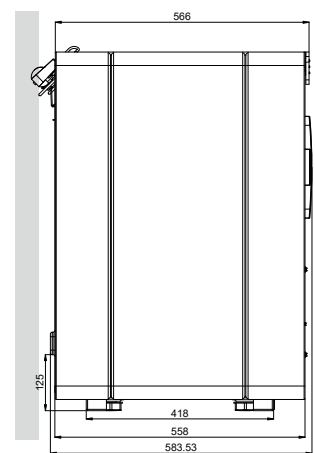

## Dimensions DucoBox Energy Comfort 325

Front view

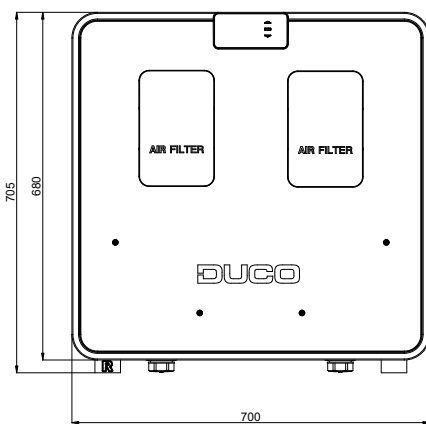

Rear view

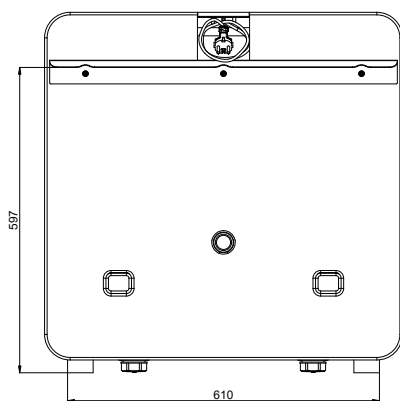

Top view

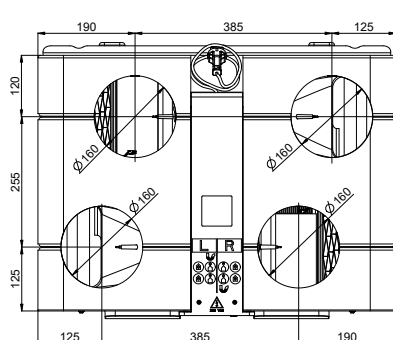

Bottom view

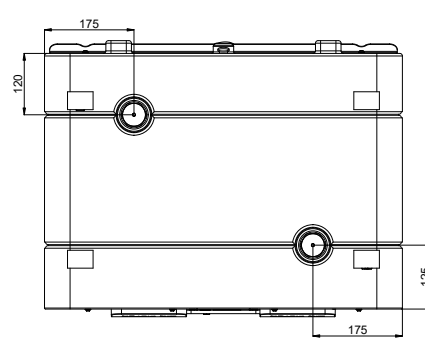

Side view

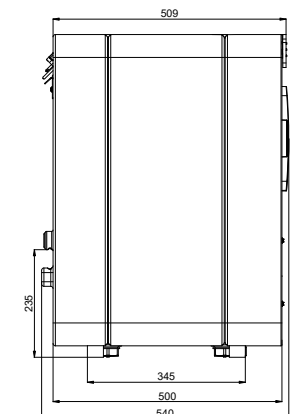



# Introducing DucoBox Energy Comfort Plus (D350/D450/D550)



In the spotlight  
one of Europe's smartest CHRV solution

## 3 models for 3 different air flows Unique for this range

- ✓ Patented principle of double by-pass
- ✓ Dynamic Airflow Filters  
For maximum efficiency.
- ✓ Low power consumption due to energy-efficient EC motors
- ✓ L/R interchangeable  
100% software-based
- ✓ Smart 2-zone control  
with external valves
- ✓ Comfort Plus  
with acoustic casing =  
10dB quieter!
- ✓ Smart demand management based on  
CO<sub>2</sub> and/or humidity measurement



# First choice for building projects

The DucoBox Energy Comfort Plus is a Centralized Ventilation unit with Heat Recovery (CHRV). This smart and even more silent ventilation unit with metallic casing can be chosen with a capacity of up to 550 m<sup>3</sup>/h.

It is the ideal solution for various sizes of houses and apartments. The left/right switch is 100% software-driven thanks to the patented principle of double bypass. The dynamic air distribution filters, together with the smart demand control based on CO and humidity, ensure for 2 exceptional efficiency within this compact unit.

## ✓ Optional pre-heater and optional multi-zoning valve

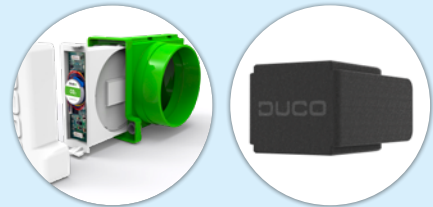

## ✓ L/R switch - 100% software-based

This unit is very user-friendly because physical interventions are not necessary. The left/right switch is carried out 100% by software thanks to a patented principle of double by-pass.

## ✓ Compact unit: 760 x 803 x 584 mm

With its compact dimensions, the DucoBox Energy Comfort is ideal for a small technical space!

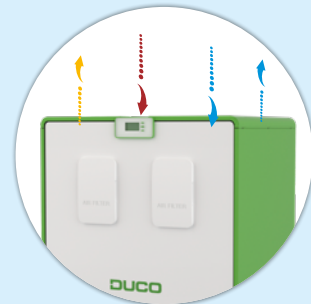

## ✓ Smart copy function

Thanks to a "copy" function which is integrated on software level, the installer has the possibility to copy the settings and parametrisation of one DucoBox Energy Comfort Plus onto the next DucoBox Energy Comfort Plus. This is particularly useful in a serial construction with the same types of houses.

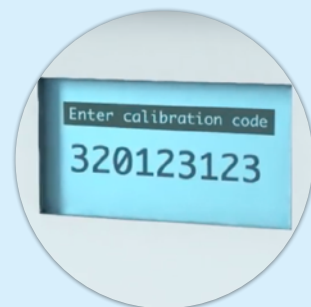

## ✓ Automatic calibration

Relying on the principles of calibration at constant pressure, this method achieves a 50% saving on calibration time. DUCO saves you time.



## ✓ Smart demand control based on CO<sub>2</sub> and/or humidity measurement

## DucoBox Energy Comfort Plus (D350/D450/D550)

The DUCO Energy Comfort Plus range is a **centralised ventilation unit with heat recovery**. DucoBox Energy Comfort Plus was developed with the aim of guaranteeing an even quieter operation. Within the DucoBox Energy Comfort range, the left/right exchange is 100% software-driven thanks to the patented principle of the double by-pass.

The demand control of the DucoBox Energy Comfort Plus D550 results in **intelligent and energy-efficient operation**. Together with the smart demand control based on CO<sub>2</sub> and humidity, the dynamic air distribution filters ensure exceptional efficiency within this compact unit.

The compact and quick-to-install 2-zone valves provide the most energy-efficient result that can be achieved with CHR.V. Please note that the zone control reduces the noise **by at least 30%**! Comfort rules!

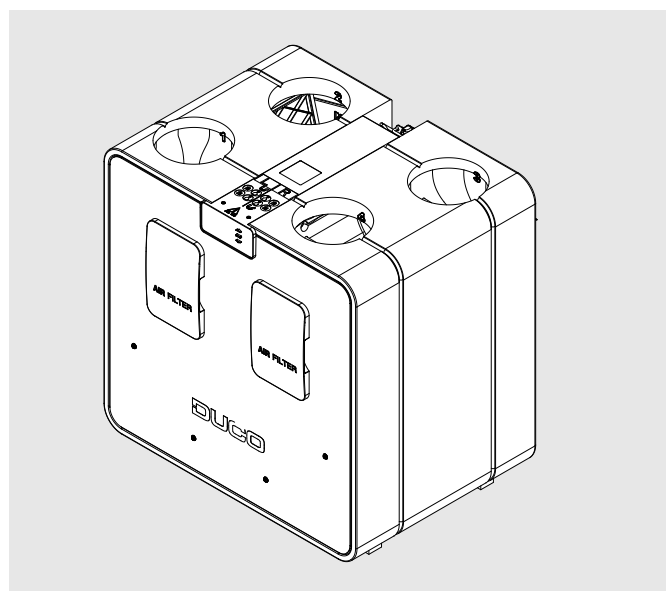

### Versions DucoBox Energy Comfort Plus D350/D450/D550

Type	Pulsion and extraction capacity at 150 Pa	Pulsion and extraction capacity at 200 Pa	2-zone system	Frost protection	Reference Number
DucoBox Energy comfort Plus D350	350 m <sup>3</sup> /h	350 m <sup>3</sup> /h	Yes (as external option)	Imbalance or optional external heater	00004704
DucoBox Energy Comfort Plus D450	450 m <sup>3</sup> /h	450 m <sup>3</sup> /h			00004705
DucoBox Energy Comfort Plus D550	550 m <sup>3</sup> /h	550 m <sup>3</sup> /h			00004706

### Optional Accessories DucoBox Energy Comfort Plus D350/D450/D550

Product	Reference Number
Pre-Heater DucoBox Energy Comfort (Plus) - 1,425W	00004807
Multizone Valve DucoBox Energy Comfort (Plus) (Sensorless) Ø125	00004761
Multizone Valve DucoBox Energy Comfort (Plus) (Sensorless) Ø160	00004760
Siphon flat	00004376
Connectivity Board Modbus and WIFI	00004810
Humidity Sensor (Energy Comfort & Energy Comfort Plus)	00004723
Standing chair (Energy Comfort D400/Plus)	00004740
Filterset 2 x Coarse 65 % (Energy Comfort D400 & Plus D350/D450/D550)	00004741
Filterset Coarse 65% / ePM1 55% (Energy Comfort D400 & Plus D350/D450/D550)	00004742
Coaxial cable set 8m (Energy Premium / Comfort / Comfort Plus)	00004418
Duco Wired power adapter 230VAC-24VDC/20W	00004762
Power supply 230VAC-24VDC/20W + housing	00004763
Muff with rubber D180/D160 (M/M) [connection piece with joint]	00004725
Muff with rubber D180/D180 (M/M) [connection piece with joint]	00004726
Muff with rubber D200/D180 (M/M) [connection piece with joint]	00004727

# DucoBox Energy Comfort Plus

## D350-D450-D550

More details and final information can be found by scanning or clicking the QR codes.



DucoBox Energy Comfort Plus

Physical Properties			
Width x Height x Depth (mm)	760 x 803 x 584 mm		
Casing	Coated sheet steel		
Colours	White + Green		
Connections	Inner Diameter: Ø 180mm		
Condensate drain	Ø 32 mm (1 ¼") (2x)		
Heat exchanger	v1: PP - v2: PET/Alu		
Material of inside section	EPP / PP / ABS		
Weight	47 kg		
Power cable length	2 m (from top of unit)		
Mounting	Wall mounting (standard) Floor mounting as an option using support frame		
Miscellaneous Properties			
Energy class	With 2 sensors (control factor 0.65): A+ Other: A		
Filters	Dynamic airflow filter supply air (520 x 190 x 15 mm) Standard: ISO 16890 Coarse 65 % (= G4) Optional: ISO 16890 ePM1 55% (=F7) Dynamic airflow filter exhaust air (520 x 190 x 15 mm) Standard: ISO 16890 Coarse 65 % (= G4)		
Summer by-pass	Fully (100% modulating)		
Frost protection	Imbalance or external heater		
Fans	EC fan with backward curved blades		
Automatic Calibration	Yes (constant pressure)		
Constant flow regulation	Yes		
Passive cooling	Automatic passive cooling control		
Operation	Integrated display Use via User controllers and CO <sub>2</sub> or Humidity Sensors Via smartphone / tablet as an option (provided device has Communication Print)		
Sensors	Integrated: pressure, temperature, onboard switch sensor External: CO <sub>2</sub> (via optional Sensor), Humidity (via optional Sensor or measurement in ETA line), external Switch Sensor (voltage free input) (optional)		
Communication	Standard: Duco RF, Duco Wired, Switch Sensor Expandable with Communication Print: ModBus, PWM-IN, PWM-OUT, Switch Sensor (3x), Ethernet, Micro SD-card slot		
Electrical Characteristics	D350	D450	D550
Maximum electrical power	117 W (2 x 58.5 W)	196 W (2 x 98 W)	276 W (2 x 133.5 W)
Power Supply	230 V, 50 Hz Via 3-core power cable with earthed plug		
Contacts	0-10 V in/output		
Type of motor	DC		
Energy conversion efficiency	At 350 m <sup>3</sup> /h: 84% At 307 m <sup>3</sup> /h: 85% At 255 m <sup>3</sup> /h: 86%	At 450 m <sup>3</sup> /h: 81% At 418 m <sup>3</sup> /h: 82% At 377 m <sup>3</sup> /h: 83%	At 550 m <sup>3</sup> /h: 78% At 515 m <sup>3</sup> /h: 79% At 471 m <sup>3</sup> /h: 80%



## Dimensions DucoBox Energy Comfort Plus D350

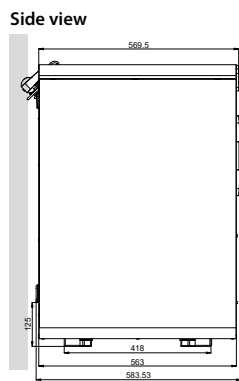
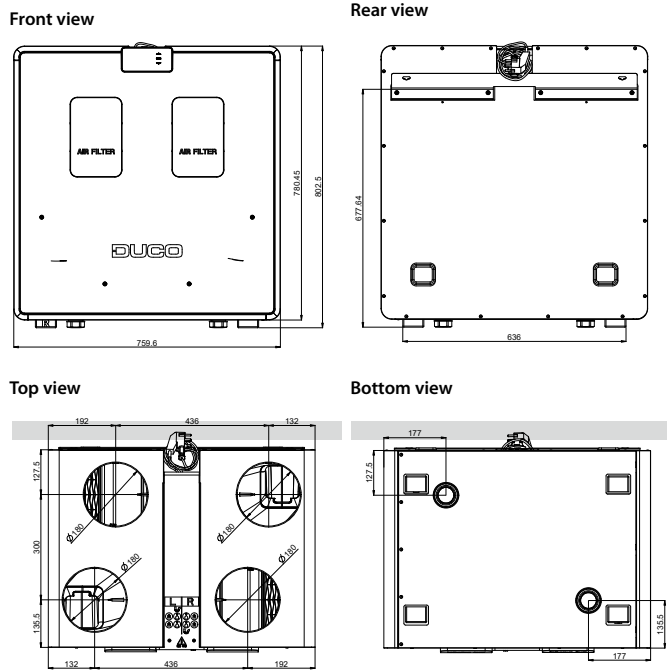

## Dimensions DucoBox Energy Comfort Plus D450

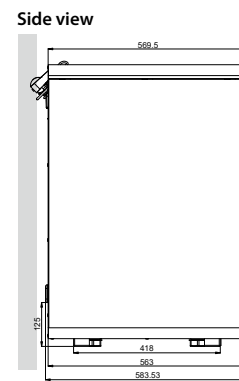
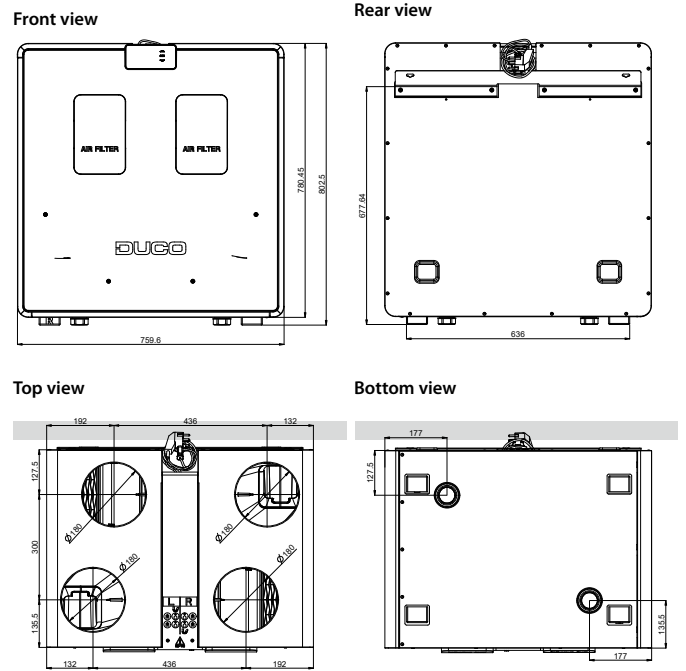

## Dimensions DucoBox Energy Comfort Plus D550

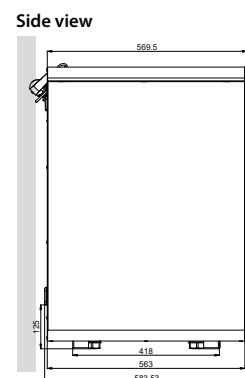
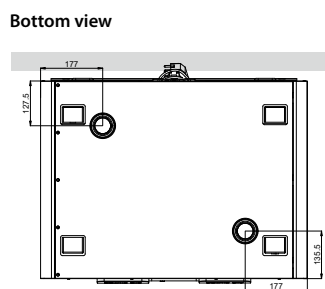
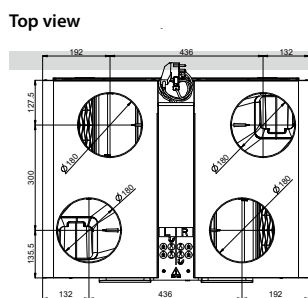
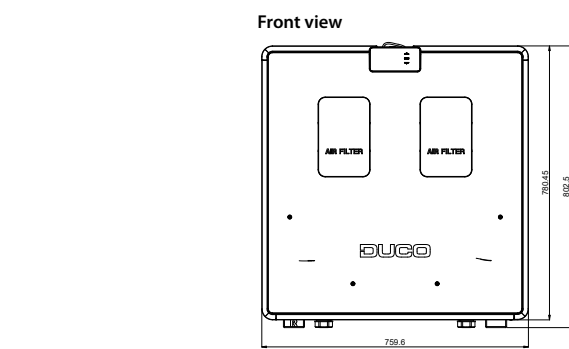



# DucoBox Energy Premium

The DucoBox Energy Premium raises CHRV with heat recovery to the next level. Ideal for installation in an energy-neutral home of the future, automatic calibration and integrated 2-zone control with demand control ensure ultra-quiet, intelligent and energy-saving operation.

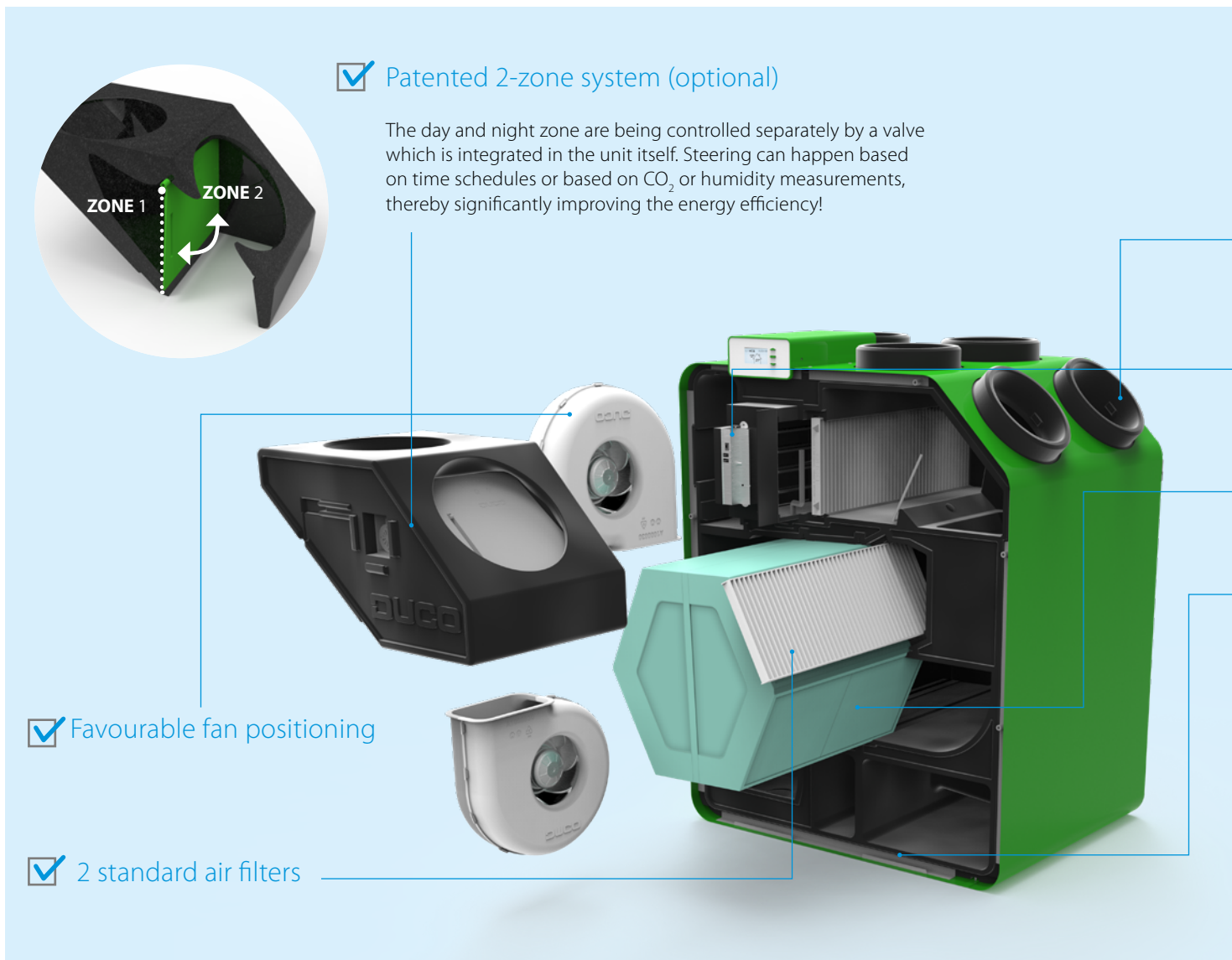

## ✓ Patented 2-zone system (optional)

The day and night zone are being controlled separately by a valve which is integrated in the unit itself. Steering can happen based on time schedules or based on CO<sub>2</sub> or humidity measurements, thereby significantly improving the energy efficiency!

## ✓ Favourable fan positioning

## ✓ 2 standard air filters

## ✓ Distinguishing features

- › Demand-controlled balanced system with **heat recovery**
- › **Lowest** sound power (air supply) in the market
- › Patented **2-zone control** guarantees maximum energy efficiency (60.5 W)
- › Automatic calibration reduces installation time by **at least 50%**
- › **Modular** set-up of on-demand **components**
- › Minimum number of components
- › **Smart communication** with domotic systems through ModBus or ethernet



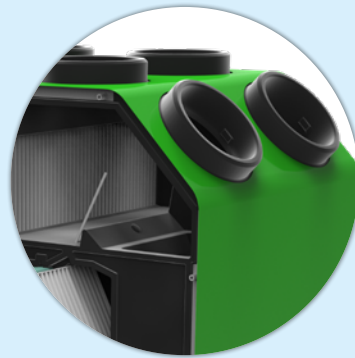

✓ Smart humidity measurement & pressure sensors

✓ Intelligent preheater

✓ Heat exchanger for maximum efficiency

✓ Low noise guaranteed

✓ Automatic calibration

The automatic calibration, which is based on the principle of constant pressure, allows for a very fast and accurate calibration. This easily reduces set-up time to 50%! DUCO saves you time and money.



# DucoBox

## Energy Premium 325 - 400

The DucoBox Energy Premium is a mechanical ventilation unit with heat recovery. It mechanically supplies fresh air to the house and mechanically extracts contaminated air from it with the help of integrated fans. During this process, the heat is recovered from the extracted air and transferred to the supplied air.

The **smart demand control** of the DucoBox Energy Premium results in quiet, intelligent and energy efficient operation.

**Control components** can be paired with the DucoBox Energy Premium (= master unit).



The DucoBox Energy Premium features frost protection system (with or without heater), bypass function and constant flow.

The **automatic calibration** ensures the device can be installed quickly.

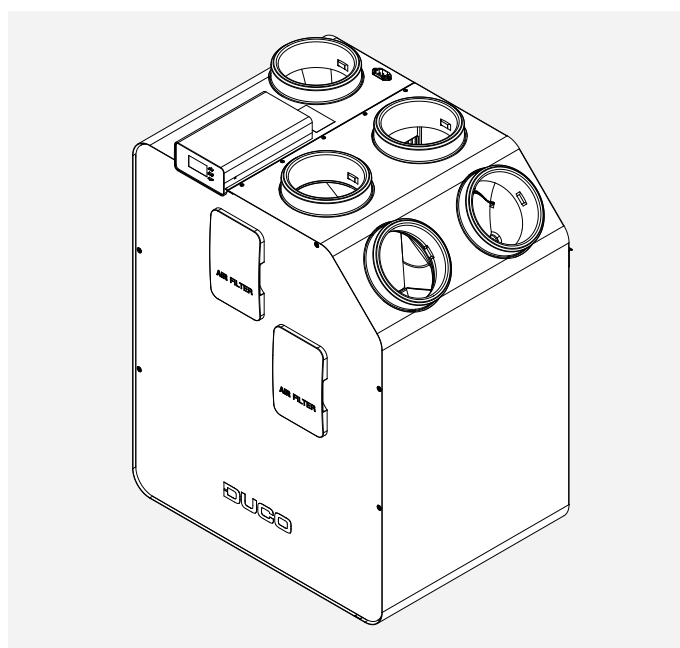
The DucoBox Energy Premium is available as both a 1-zone and a 2-zone variant, with the latter providing even quieter and more energy-efficient operation.



### Versions

Type	Supply and exhaust capacity at 150 Pa in m <sup>3</sup> /h	2-zone system	Frost protection	Reference number	
				 LEFT	 RIGHT
DucoBox Energy Premium 325-1ZS	325	No	Imbalance	00004358	00004359
DucoBox Energy Premium 325-1ZH			Imbalance + heater	00004360	00004361
DucoBox Energy Premium 325-2ZS		Yes	Imbalance	00004362	00004363
DucoBox Energy Premium 325-2ZH			Imbalance + heater	00004364	00004365
DucoBox Energy Premium 400-1ZS	400	No	Imbalance	00004366	00004367
DucoBox Energy Premium 400-1ZH			Imbalance + heater	00004368	00004369
DucoBox Energy Premium 400-2ZS		Yes	Imbalance	00004370	00004371
DucoBox Energy Premium 400-2ZH			Imbalance + heater	00004372	00004373

For UK models, see page 18

### Optional accessories premium 400

Product	Reference number
Mounting chair standing (Energy Premium)	00004421
Mounting chair hanging (Energy Premium)	00004422
Siphon flat (Energy & Eco)	00004376
Communication Print	00004251
Humidity Sensor (Energy Premium)	00004374

# DucoBox

## Energy Premium 325 - 400

More details and final information can be found by scanning or clicking the QR codes.



DucoBox Energy Premium

<b>Physical properties</b>		<b>325</b>	<b>400</b>
Width x Height x Depth (mm)	740 x 957 x 585 mm		
Casing	Coated sheet steel		
Colours	White + green		
Connections	Interior diameter: Ø 160 mm - Exterior diameter: Ø 190 mm		
Condensate drain	Ø 32 mm (1 ¼")		
Heat exchanger	PET / Polystyrene		
Interior material	EPP / PP / ABS		
Weight	47 kg		
Power plug cable length	2 m (connected at the top side of the unit)		
Mounting	Wall mounting (standard) Floor mounting as an option using support frame		
<b>Miscellaneous properties</b>		<b>325</b>	<b>400</b>
Energy class	Control factor 0.65: A+ Other: A		
Filters	Filter supply air (175 x 500 x 25 mm) Standard: ISO 16890 Coarse 65 % (≈ G4) Optional: ISO 16890 ePM1 70% (≈ F7) Filter exhaust air (175 x 500 x 25 mm) Standard: ISO 16890 Coarse 65% (≈ G4)		
Summer bypass	Full (100% modulating)		
Frost protection	Imbalance - Optional via proportional Heater		
Fans	EC fan with curved blades		
Automatic configuration	Yes (constant pressure)		
Constant flow control	Yes		
Controls	Integrated display Use via control switches and room sensors Optionally via smartphone / tablet (if Communication Print in device)		
Sensors	Integrated: pressure, temperature, humidity (via optional box sensor), onboard switch contact External: CO <sub>2</sub> (via optional room sensor), humidity (via optional room sensor), external switch contact (voltage-free input) (optional)		
Communication	Standard: DUCO RF, DUCO Wired, Switch contact Can be expanded with Communication Print: ModBus, PWM-IN, PWM-OUT, Switch contact (3x), Ethernet, Micro SD-card slot		
<b>Electrical characteristics</b>		<b>325</b>	<b>400</b>
Maximum electrical capacity at 150 Pa	120 W (2 x 60 W)	183 W (2 x 91.5 W)	
Maximum electrical capacity heater	1,000 W		
Power supply	230 V, 50 Hz - via 3-core cable with earth plug		
Plugs	0-10 V in/outputs		
Motor type	DC		
IP class	IP40		
Efficiency	At 228 m <sup>3</sup> /h: 87 % At 275 m <sup>3</sup> /h: 86 % At 332 m <sup>3</sup> /h: 85 %	At 301 m <sup>3</sup> /h: 85 % At 351 m <sup>3</sup> /h: 85 % At 401 m <sup>3</sup> /h: 84 %	



**Left model**

Front view

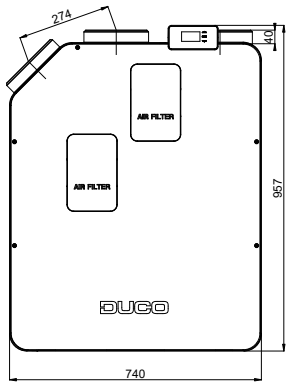

Rear view

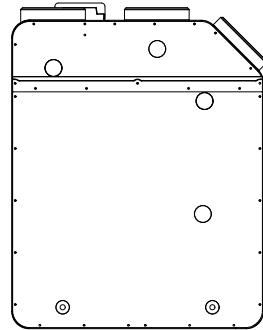

Side view

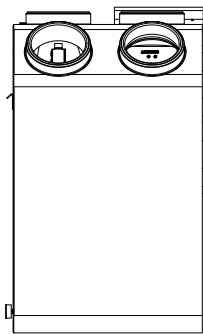
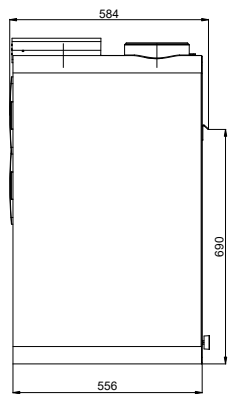

Top view

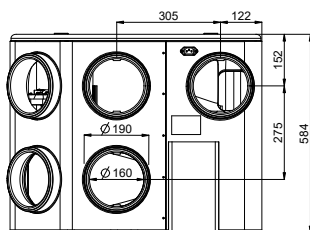

Bottom view

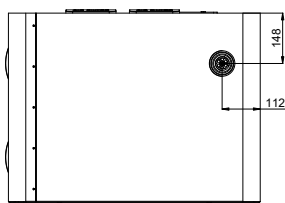

**Right model**

Front view

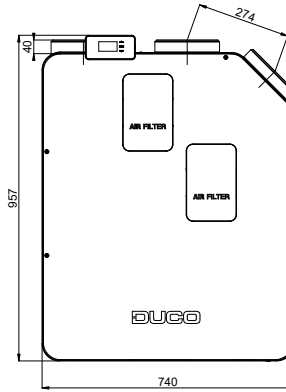

Rear view

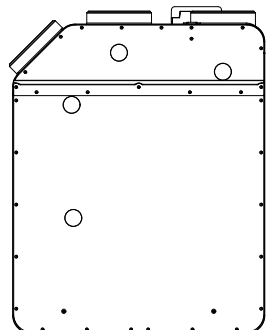

Side view

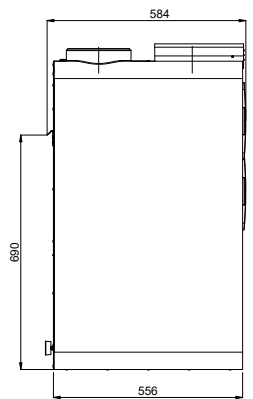
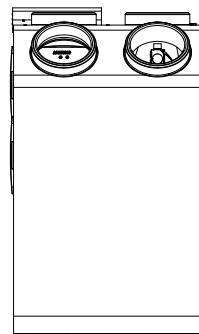

Top view

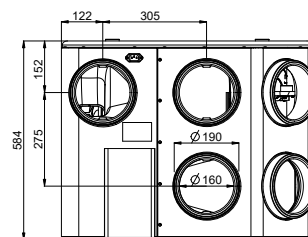

Bottom view

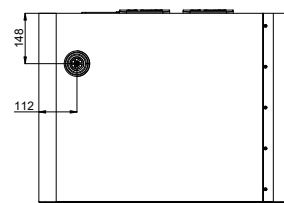

# Total ventilation package

Are you looking for a total ventilation package? Then you are best going to just one address. With DucoFlex, Daikin provides a complete air duct system for CHRV. When you use DucoFlex, you will also benefit from the 'Zero Noise' guarantee package. This consists of the highest airtightness class D, the lowest air resistance and maximum acoustic comfort with the quietest ventilation system in Europe! The result is an energy-efficient and quiet ventilation system.

Did you know that this complete air duct system is very easy to install? This is thanks to the handy 'Click & Go' principle and minimum number of fittings. Daikin as a one-stop-shop with 100 % service provision.

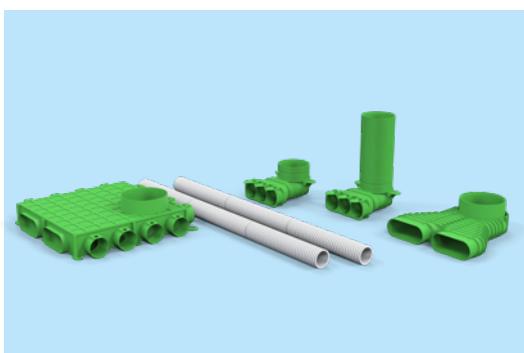
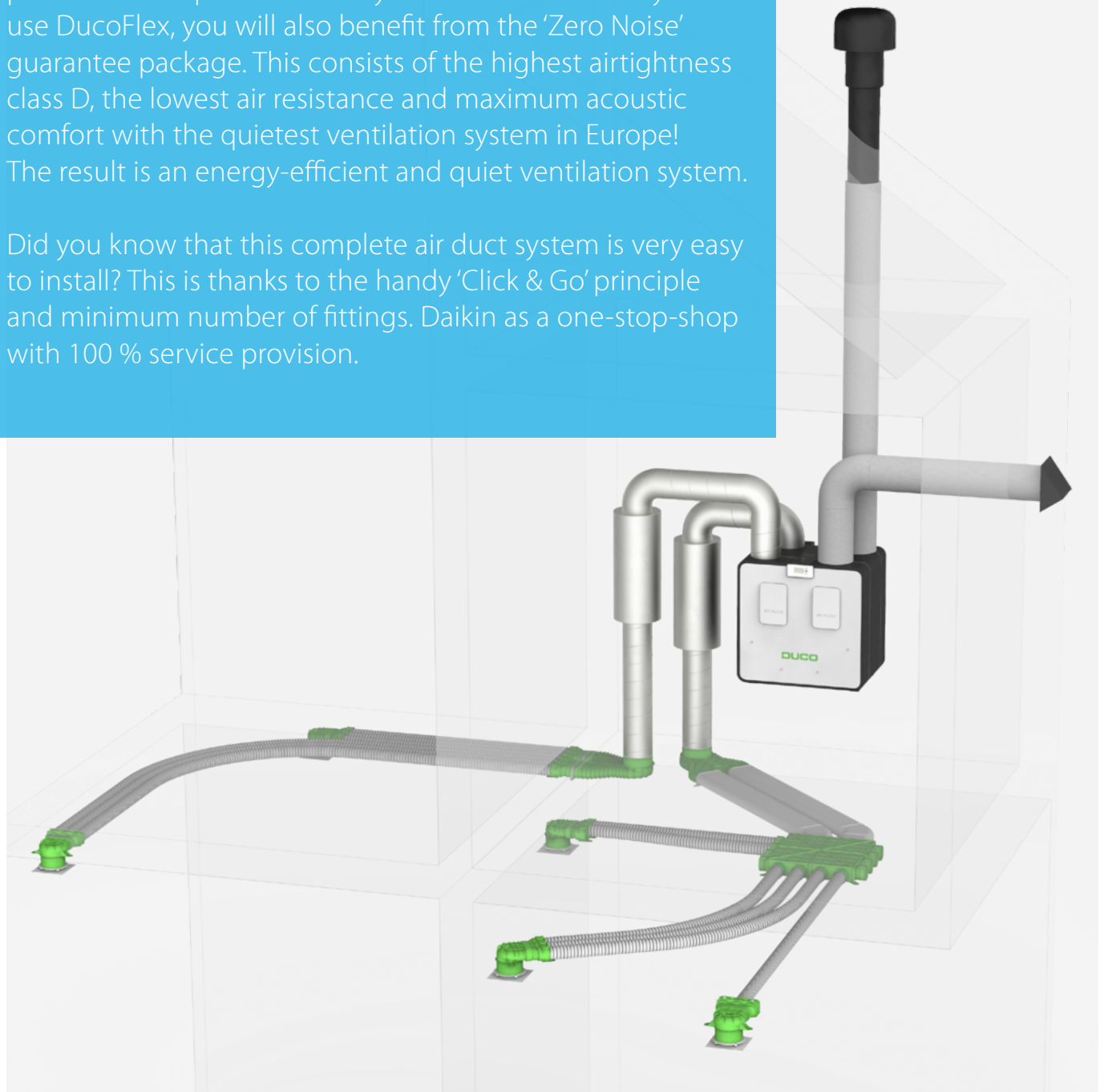

- ✓ **DucoFlex**  
Complete air ducting system for CHRV
- ✓ **'Click & Go' system**  
Flexible ducting with convenient click system
- ✓ **'Zero noise' guarantee**  
Meets the most stringent requirements
- ✓ **100% service**  
Complete ventilation package with support

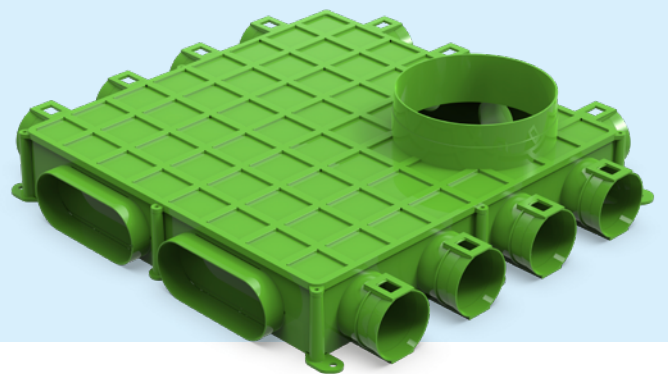
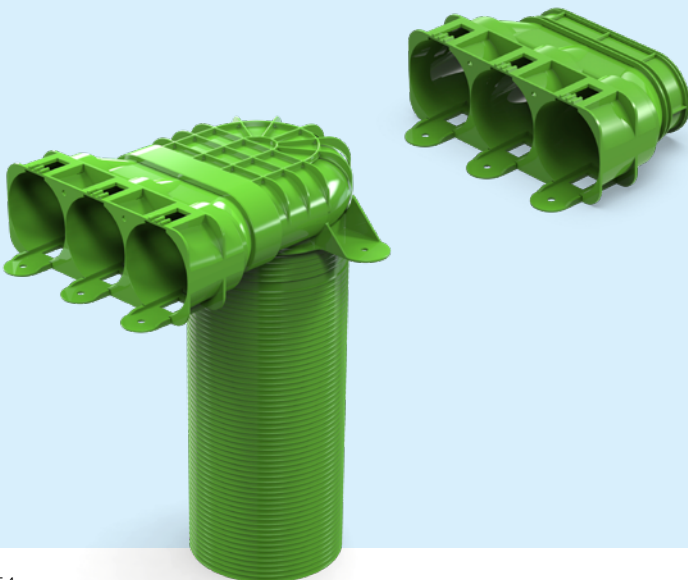
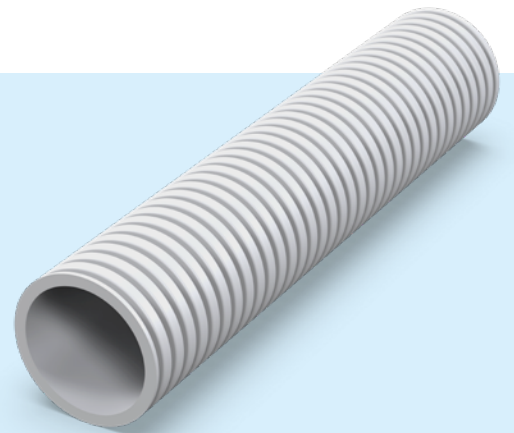
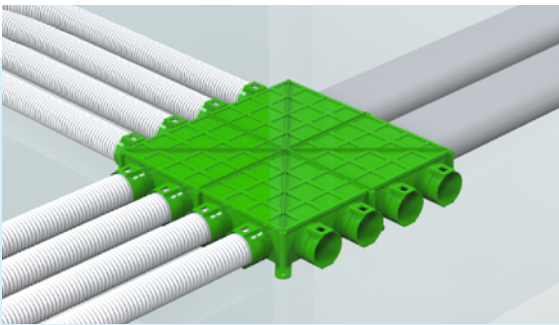



# Offering ducoflex accessories to provide you a total solution for your ventilation needs

With the arrival of the DucoFlex air duct system, thanks to DUCO, Daikin can provide a total residential ventilation solution. From vents, to ducts and including a complete range of ventilation boxes. In short, together with DUCO, we have all we need in-house for a high-quality residential ventilation system.

## Supply and exhaust vents

A wide range of supply and exhaust vents with a fitting diameter of  $\varnothing 125$  mm. Duco vents distinguish themselves through simple calibration, fast installation, aesthetics, acoustics and easy maintenance.



## Silencers

**Flexible or rigid attenuators** that have pre-fitted connectors. Thanks to their sound-reducing properties, the DucoFlex attenuators are an essential part of the "Zero Noise" guarantee package from Duco.



## Wall and roof feed-through

A complete range of roof and wall feed-throughs, available in different materials and colours. The connection diameters of  $\varnothing 160$  mm and  $\varnothing 180$  mm are in line with that of most conventional riser ducts and DucoFlex insulated ventilation ducts.



## Insulated ducting

The range of insulated EPP and EPS ducts with a diameter of  $\varnothing 160$  mm or  $\varnothing 180$  mm are simple to connect to Duco's air duct system. With a limited number of parts, it's easy to create a thermally **insulated connection** between the ventilation unit and the roof/wall feed-through.

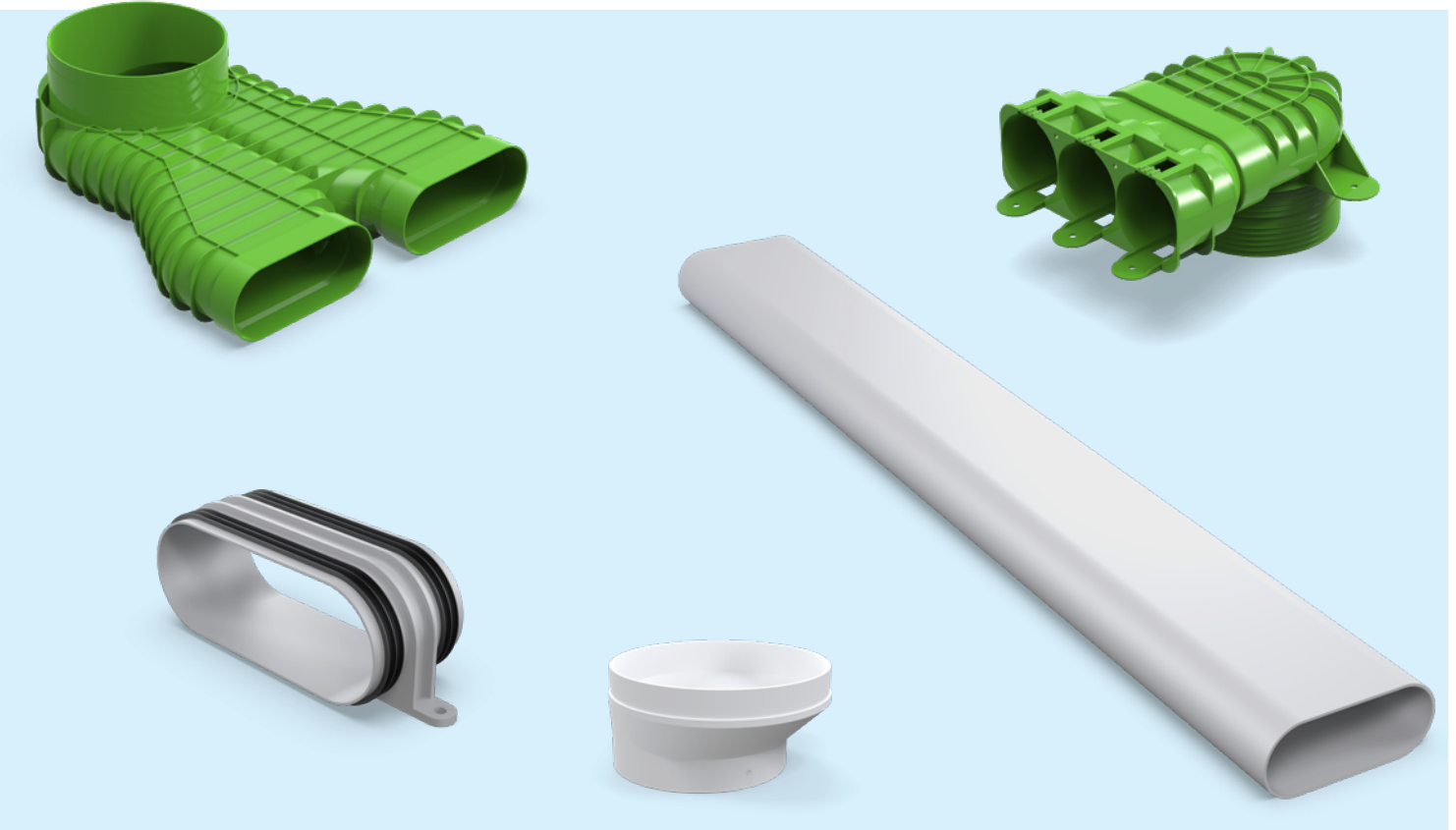

## DucoBox Energy Series



### DucoBox Energy Premium

Article Number	Description
00004358	DucoBox Energy Premium 325 - 1ZS Left
00004360	DucoBox Energy Premium 325 - 1ZH Left
00004366	DucoBox Energy Premium 400 - 1ZS Left
00004368	DucoBox Energy Premium 400 - 1ZH Left
00004362	DucoBox Energy Premium 325 - 2ZS Left
00004364	DucoBox Energy Premium 325 - 2ZH Left
00004370	DucoBox Energy Premium 400 - 2ZS Left
00004372	DucoBox Energy Premium 400 - 2ZH Left
00004359	DucoBox Energy Premium 325 - 1ZS Right
00004361	DucoBox Energy Premium 325 - 1ZH Right
00004367	DucoBox Energy Premium 400 - 1ZS Right
00004369	DucoBox Energy Premium 400 - 1ZH Right
00004363	DucoBox Energy Premium 325 - 2ZS Right
00004365	DucoBox Energy Premium 325 - 2ZH Right
00004371	DucoBox Energy Premium 400 - 2ZS Right
00004373	DucoBox Energy Premium 400 - 2ZH Right



### DucoBox Energy Comfort Plus

Article Number	Description
<b>NEW</b> 00004706	DucoBox Energy Comfort Plus D550
<b>NEW</b> 00004705	DucoBox Energy Comfort Plus D450
<b>NEW</b> 00004704	DucoBox Energy Comfort Plus D350



### DucoBox Energy Comfort

Article Number	Description
<b>NEW</b> 00004707	DucoBox Energy Comfort D400
00004485	DucoBox Energy Comfort 325 (Name will change during FY24 to 00004649 and Comfort D325)
<b>NEW</b> 00004657	DucoBox Energy Comfort D325 FR (NF Unit: France only)

## Controllers, sensors, ...

Article Number	Description
00004174	Switch sensor (Energy Premium / Comfort / Comfort Plus)
00004374	Humidity Sensor (Energy Premium)
00004723	Humidity Sensor (Energy Comfort & Energy Comfort Plus)
00004603	CO <sub>2</sub> Sensor RF / Wired (User control + Air quality measurement - Black)
00004604	CO <sub>2</sub> Sensor RF / Wired (User control + Air quality measurement - White)
00004605	Humidity Sensor RF / Wired (User control + Air quality measurement - Black)
00004606	Humidity Sensor RF / Wired (User control + air quality measurement - White)
00004175	User controller RF / Battery (Black)
00004600	User controller RF / Battery (White)
00004601	User controller RF / Wired (Black)
00004602	User controller RF / Wired (White)
00004636	CO <sub>2</sub> Room sensor without control RF/Wired (Air quality measurement only - Black)
00004637	CO <sub>2</sub> Room sensor without control RF/Wired (Air quality measurement only - White)



## DucoVent Basic, Comfort, Design, ...

Article Number	Description
00004178	DucoVent Basic (supply and exhaust)
<b>NEW</b> 00004769	DucoVent Comfort
00004179	DucoVent Design square standard AK (exhaust) - RAL 9010
00004226	DucoVent Design square XL AK (supply and exhaust) - RAL 9010
00004210	DucoVent Design round AK (supply and exhaust) - RAL 9010
00004211	DucoVent Design rounded square standard AK (exhaust) - RAL 9010
00004227	DucoVent Design rounded square XL AK (supply and exhaust) - RAL 9010
10300800	DoorVent RAL 9001
10300700	DoorVent RAL 9010

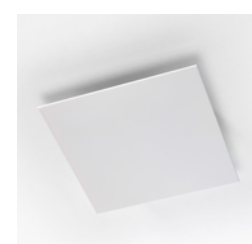

## Options & accessories

### Filters, siphons, mounting chair, ...

Article Number	Description
00004376	Siphon flat (Energy Premium & Comfort)
00004422	Mounting chair hanging (Energy Premium)
00004546	Mounting chair standing (Energy Comfort D325)
<b>NEW</b> 00004740	Standing chair (Energy Premium / Comfort D400/Plus)
00004418	Coaxial cable set 8m (Energy Premium / Comfort / Comfort Plus)



### Power adapter/power supply

Article Number	Description
<b>NEW</b> 00004762	Duco Wired power adapter 230VAC-24VDC/20W
<b>NEW</b> 00004763	Power supply 230VAC-24VDC/20W + housing



### Filters

Article Number	Description
00004417	Filter set 2 x Coarse 65 % (Energy Premium)
00004416	Filter set Coarse 65 % / ePM1 70 % (Energy Premium)
<b>NEW</b> 00004661	Filterset Coarse 65% / ePM1 55% (Energy Comfort D325)
00004547	Filter set 2 x Coarse 65 % (Energy Comfort D325)
<b>NEW</b> 00004741	Filterset 2 x Coarse 65 % (Energy Comfort D400 & Plus D350/D450/D550)
<b>NEW</b> 00004742	Filterset Coarse 65% / ePM1 55% (Energy Comfort D400 & Plus D350/D450/D550)





Pre-heater & Multizone Valve

Article Number	Description
<b>NEW</b> 00004807	Pre-Heater DucoBox Energy Comfort (Plus) - 1,425W (available from 1/4/2023)
<b>NEW</b> 00004825	Pre-Heater DucoBox Energy Comfort (Plus) UK - 1,425W (available from 1/4/2023)
<b>NEW</b> 00004761	Multizone Valve DucoBox Energy Comfort (Plus) (Sensorless) Ø125
<b>NEW</b> 00004760	Multizone Valve DucoBox Energy Comfort (Plus) (Sensorless) Ø160



Communication prints



Article Number	Description
00004251	Communication print (Energy Premium & Comfort)
<b>NEW</b> 00004810	Connectivity Board; Modbus; WIFI

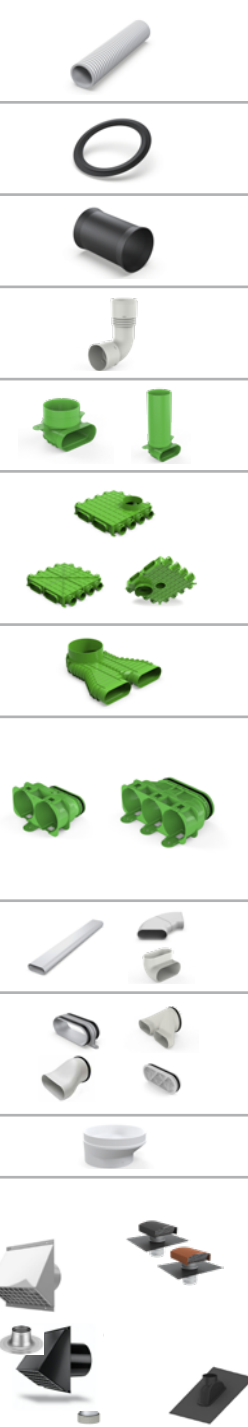

DucoFlex Standard Components

Article Number	Description
00004552	DucoFlex round semi-rigid duct D63 (50 m)
00004674	DucoFlex round semi-rigid duct D75 (50 m)
00004692	DucoFlex round semi-rigid duct D90 (50 m)
00004553	DucoFlex rubber O-ring D63 (10 pieces)
00004675	DucoFlex rubber O-ring D75 (10 pieces)
00004676	DucoFlex rubber O-ring D90 (10 pieces)
00004554	DucoFlex Coupling D63
00004677	DucoFlex Coupling D75
00004678	DucoFlex Coupling D90
00004679	DucoFlex Elbow 90° D75
00004680	DucoFlex Elbow 90° D90
00004681	DucoFlex 90° Bend splitter vent connector long - oval/D125
00004682	DucoFlex 90° Bend splitter vent connector short - oval/D125
00004563	DucoFlex Manifold box (floor) 12x63 D180
00004564	DucoFlex Manifold box (ceiling) 12x63 D180
00004565	DucoFlex Manifold box (floor) 12x63 + 2 x oval air ducts
00004701	DucoFlex Manifold box (floor and ceiling) 3 x oval air ducts (F) + 1 x oval air duct (M)
00004687	DucoFlex Manifold box (floor and ceiling) 4 x oval air ducts (F) D160
00004566	DucoFlex connector riser round D160 - 2 oval
00004684	DucoFlex Adapter 3x63 oval
00004685	DucoFlex Adapter 2x75 oval
00004841	DucoFlex Adapter 3x75 oval
00004686	DucoFlex Adapter 2x90 oval
00004555	DucoFlex clamp coupling D63
00004829	DucoFlex clamp coupling D75/D90
00004567	DucoFlex oval air duct B163xH68xL1,150
00004609	DucoFlex horizontal elbow 90°/45° rigid oval duct
00004699	DucoFlex vertical elbow 90° rigid oval duct
00004568	DucoFlex oval duct coupling
00004638	DucoFlex horizontal connector oval - D125
00004700	DucoFlex horizontal connector D160 2 x oval
00004713	DucoFlex Oval Cap
00004543	Reducer 160 / 125
00004542	Reducer 125 / 80
00004627	DucoFlex Wall feed-through D160 white
00004584	DucoFlex Wall feed-through D160 black
00004628	DucoFlex Wall feed-through D180 white
00004585	DucoFlex Wall feed-through D180 black
00004582	DucoFlex Roof feed-through Compact D160 - Slate
00004580	DucoFlex Roof feed-through Compact D160 - Terracotta
00004578	DucoFlex universal roof feed-through D160/180 (1.0 m)
00004581	DucoFlex Roof feed-through plate flat roof D204
00004579	DucoFlex universal roof feed-through tile D205

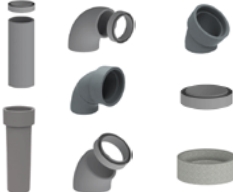

Article Number	Description	
00004586	DucoFlex Silencer flexible D125 L1,000	
00004630	DucoFlex Silencer flexible D125 (M/F) L1,000	
00004631	DucoFlex Silencer flexible D160 (M/M) L1,000	
00004632	DucoFlex Silencer flexible D180 (M/M) L1,000	
00004587	DucoFlex Silencer semi rigid D160 (M/M) L1,000 mm	
00004588	DucoFlex Silencer semi rigid D180 (M/M) L1,000 mm	
00004724	Muff with rubber D160/D160 (M/M) [connection piece with joint]	
00004725	Muff with rubber D180/D160 (M/M) [connection piece with joint]	
00004726	Muff with rubber D180/D180 (M/M) [connection piece with joint]	
00004727	Muff with rubber D200/D180 (M/M) [connection piece with joint]	
00004569	DucoFlex insulated circular duct with integrated coupler D160 L1,000	
00004570	DucoFlex insulated circular duct with integrated coupler D180 L1,000	
00004571	DucoFlex insulated 90° bend with integrated coupler D160	
00004572	DucoFlex insulated 90° bend with integrated coupler D180	
00004573	DucoFlex insulated 45° bend with integrated coupler D160	
00004574	DucoFlex insulated 45° bend with integrated coupler D180	
00004575	DucoFlex insulated coupler D160	
00004576	DucoFlex insulated coupler D180	

## Tools

Article Number	Description
00004599	DucoFlex Tube cutter D63
00004688	DucoFlex Tube cutter D75
00004689	DucoFlex Tube cutter D90

